

# RADIO CONSTRUCTOR

1'3  
Vol. 3 No. 8  
MARCH  
1950

*For Every Radio Enthusiast*

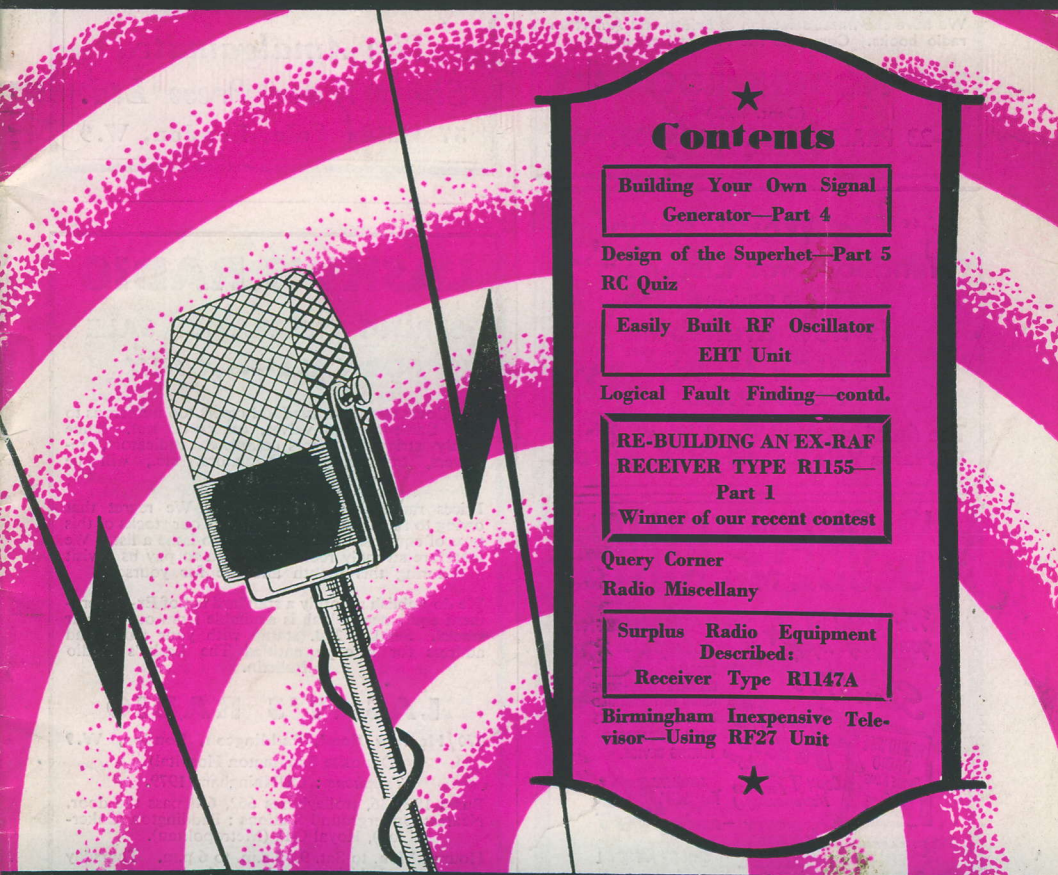

## Contents

Building Your Own Signal  
Generator—Part 4

Design of the Superhet—Part 5  
RC Quiz

Easily Built RF Oscillator  
EHT Unit

Logical Fault Finding—contd.

RE-BUILDING AN EX-RAF  
RECEIVER TYPE R1155—  
Part 1  
Winner of our recent contest

Query Corner  
Radio Miscellany

Surplus Radio Equipment  
Described:  
Receiver Type R1147A

Birmingham Inexpensive Tele-  
visor—Using RF27 Unit



AN AMALGAMATED-SHORT WAVE PRESS PUBLICATION

**—THESE ARE IN STOCK—**

- Television Explained. By W. E. Miller. 5s. Postage 5d.  
 Practical Wireless Circuits. By F. J. Camm. 6s. Postage 5d.  
 Fundamentals of Radio-Valve Technique. By J. J. Deketh. 35s. Postage 1s.  
 Amateur Radio Receivers. By S. K. Lewer. 3s. 6d. Postage 2d.  
 Radio Valve Data Compiled by the "Wireless World." 3s. 6d. Postage 3d.  
 Basic Television. By Bernard Grob. 55s. 6d. Postage 1s.  
 Frequency Modulated Radar. By D. G. C. Luck. 34s. Postage 1s.  
 Amateur Radio Simple Transmitting Equipment. By W. H. Allen and J. W. Mathews. 2s. Postage 2d.  
 Recent Advances in Radio Receivers. By L. A. Moxon. 18s. Postage 6d.  
 The Radio Amateur's Handbook. By A.R.R.L. 15s. 6d. Postage 9d.  
 The Technique of Radio Design. By E. E. Zepler. 25s. Postage 9d.  
 A Home Built Televisor for Sutton Coldfield Reception. By W. I. Flack. 4s. 6d. Postage 3d.  
 Wireless Servicing Manual. By W. T. Cocking. 10s. 6d. Postage 5d.

We have the finest selection of British and American radio books. Complete list on application.

**THE MODERN BOOK CO.**

(Dept. R.C.)

19-23 PRAED STREET, LONDON, W.2

**"The World Radio Handbook for Listeners"**

(1950 Edition)

is now available

**PRICE 6s. 9d.**

**POST PAID**

The Amalgamated Short Wave Press  
 57 Maida Vale, London, W.9 LTD.

**'GLOBE' 'JONRAD' 'KING'**  
 SHORT-WAVE  
REGD.

*The World at your fingertips!* ★ *Real LONG DISTANCE Radio Reception* ★

Send for **FREE** COPY of Catalogue (enclose 1<sup>st</sup> stamp postage) **COMPLETE "Easy Build" KIT 49<sup>9</sup>/<sub>100</sub>d**  
 PROBABLY THE SMALLEST ONE VALVE SHORT-WAVE RADIO IN THE WORLD USING STANDARD PARTS WITH BANDSPREAD TUNING DEVICE.

**MONEY - COSTS ONLY**  
 ★ **BACK GUARANTEE** SENT ON APPROVAL

**JOHNSONS** (Radio Specialists) **MACCLESFIELD** (CHESHIRE (ENGLAND))  
TRADE & OVERSEAS ENQUIRIES INVITED Write to:-

**Short Wave News**

is a monthly journal which deals with all aspects of short wave radio. The constructional side describes short wave receivers, transmitting equipment, aerials, test apparatus, etc. The amateur and broadcast bands are covered in separate articles, each contributed by an enthusiast in each sphere, and there is usually an illustrated description of an amateur or commercial station. International Short Wave League activities are exclusively recorded in this magazine, and a number of competitions are run for the benefit of readers. Now in its fourth volume, Short Wave News is obtainable from local booksellers at 1/3, or may be subscribed for at 16/- annually.

*The Amalgamated Short Wave Press Ltd.*

57 Maida Vale, London, W.9

**LASKY'S RADIO**

**SPRING CLEARANCE SALE FOR CALLERS ONLY**

Ex.-Government chassis (odd types) too numerous to list. Some contain valves, others do not. Some partly stripped, others complete. Indicators, receivers, transmitters, modulators, etc., will be available.

Prices range from 1/6 upwards. We regret that owing to the fluctuating position of our stocks of this type of equipment we are unable to issue a list. We therefore strongly recommend you to pay us a visit during this month and see for yourself.

We do publish monthly a standard list of Ex-Government equipment which is available from our regular stocks. Send a 2½d. stamp with your name and address for a copy entitled The Lasky's Radio Bulletin.

**LASKY'S RADIO**

370 Harrow Road, Paddington, London, W.9

(Opposite Paddington Hospital)

Telephone: CUNningham 1979.

Buses 18B, 36, trolleybuses 662, 664 pass the door. Nearest Underground Stations: Paddington (Bakerloo), Royal Oak (Metropolitan).

Hours: Mon. to Sat. 9.30 a.m. to 6 p.m. Thursday half day, we close at 1 p.m.

**Come to SMITH'S of EDGWARE ROAD**  
the friendly shop for all radio components

We stock everything the constructor needs—our 25 years' experience of handling radio parts and accessories enables us to select the best of the regular lines and the more useful items from the surplus market in:—

- |   |                          |
|---|--------------------------|
| Loudspeakers and Phones   | Valves and CR Tubes      |
| Transformers and Chokes   | Cabinets and Cases       |
| Meters and Test Equipment   | Capacitors and Resistors |
| Pickups and Turntables  | Coils and Formers        |
| Switches and Dials  | Plugs and Sockets        |
| Metalwork and Bakelite  | Aerials and Insulators   |
| Books and Tools   | Motors and Generators    |
| Valve Holders and Cans  | Wires and Cables         |
| Metal Rectifiers  | Panel Lights and Fuses   |
| Sleeving, Nuts and Bolts, Tags, Clips, Grommets and all other bits and pieces |                          |

**NOTHING TOO LARGE—NOTHING TOO SMALL!**  
Everything you need under one roof — at keenest possible prices  
No general catalogue is issued owing to constantly varying stocks and prices, but we shall be pleased to quote you. Lists are available for the following lines, in which we specialise, and can thoroughly recommend:—

1. The increasingly popular "Electro-Voice" range of Transformers and Chokes. "As good as the best—yet cost little more than the cheapest!"
2. The "G.L.G." 16-gauge Aluminium Chassis. "For the man who takes a pride in his rig."
3. "K-A Products" Television Aerials. "A real engineering job."

**H. L. SMITH & CO. LTD.**  
287/9 Edgware Road, London, W.2

Telephone: Paddington 589r  
Hours 9 till 6 (Thursday, 1 o'clock)  
Near Edgware Road Stations, Metropolitan and Bakerloo

**SERVICE RADIO SPARES**  
4 LISLE STREET, LONDON, W.C.2  
GERrard 1734

TRANSFORMERS, 200/250 primary Sec. 585v HT, 120 ma, 6.3v CT, 3 amps, 4v CT, 3 amps 12/6 each. 8hy 120ma chokes 3/6 each. 6.3v 3 amp heater trans. 12/3 each. Dural telescopic aerials, 12ft. 3/6 each. Telescopic whip type aerials, 14ft. 3/6 each. Bases 1/6 each. Plessey 5in. P/M Speaker without transformer, 3 ohm speech coil 9/6 each, with transformer 12/6. .02 mfd. Condensers, 5K working, Limited stock 3/- each. .5 ma centre zero meters. 3½ in. scale 22/6 each. 5 ma centre zero meters. 2½ in. scale 10/6 each. Small sensitive DP DT 6v relays, new 4/6 each. Large selection of other types of relays in stock. 0-1 ma 2½in. diam. 12/6. 0-1ma 3½in. scale 37/6. 2½in. 5-0-5v 10/6. Telesonic receiver, ideal for conversion to personal receivers. New and complete with 4 Hivac 1.5v valves 37/6 each. Bendix 522 transmitter chassis with 2.832 Bases, chokes, mod. transformers, resistors, etc. 4/6 each. V.C.R. 97 holders wired with condensers and bracket 1/6 each. .02 8kv 4/6 each. We carry large stocks of condensers and resistances of all values at competitive prices. Send us your enquiries.  
LT Transformers 6v, 12v, 24v, 40v, 1-10 amps in stock from 18/6. New. Special types wound at short notice. Auto transformers from 60w up to 5kva in stock. 12v AC DC motors, ideal for models, etc. 7/6 each. Special offer of 1/20 hp AC motors, 200/250v. Suitable for sewing machines, etc. 40/- each. Large selection of AC/DC Gram motors, AC Auto Record Changers, latest "Collaro" from £10/15/0 each, inc. P.T. Pick-ups, etc. Send us your enquiries for ex-Govt. valves of all types. Transmitting valves also in stock. Postage extra on all goods.

**GARLAND RADIO**

2in. Meters: 0-500uA DC cal. 0-15v and 0-600v. Used tested surplus, 4/- each: 0-50mA DC new, 5/6; 0-300v DC new, 5/6. Plugs and Sockets: B and L 7-pin male P and S, 2/-; 7-pin female P and S, 2/-; 10-pin Male P and S, 2/-.

Headphones: L/R Balanced Armature, per pair, 5/-; L/R Magnetic, per pair, 3/3.

H/D Vitreous W/W Resistors: 2Ω, 2.4Ω, 4Ω at 10w, 9d; 14Ω, 15Ω, 31.5Ω at 6w, 9d; 100Ω, 200Ω at 6w, 1/-; 3.2KΩ, 7.5KΩ, 30KΩ at 12w, 1/6; 10KΩ at 25w, 2/-; 430Ω, 10KΩ, 20KΩ at 75w, 3/-.

Cracked Carbon Resistors: 1.5KΩ 1% ¼w, 4KΩ 2% ½w, 10KΩ 2% ½w, 9d. each; 75KΩ 5% ¼w, 6d. each.

Mains Transformers: P. 0-200-230-250v. S. 350-0-350 at 80mA 6.3v 3A, 5v 2A. Semishroud, drop through, 17/6.

TX Valves: 8012, 10/-; TT11, 6/-; VU111, 7/6; CV54, 5/-; RK34, 5/-; 7193, 2/6.

Blower Motors: 24v DC, 7/6 each.

Rotary Converters: Input 23-24v DC Output 230v 50cps. 75w. Perfect condition, 20/- (plus 5/- carriage).

☐ Please include post or carriage all orders.

Garland Radio, Chesham House,  
Dept. RC,

Deptford Broadway, London, S.E.8

Phone: TIDeway 4412/3

*Henry's* Radio Component Specialists

A SIGNAL TRACER at minimum cost. An easy-to-build unit that can be used for R.F., I.F. and Audio signal tracing, without any switching or tuning. Highly sensitive, easy-to-build, responds to signals picked up from an ordinary receiving aerial. The circuit is that of a high-gain, 3-stage resistance-coupled audio frequency amplifier, with a 5in. speaker in the Output of the Power Amplifier stage.

We shall be pleased to supply a complete kit for the construction of the above, right down to the last nut and bolt, for the low price of £3/18/6. Concise instruction and circuits are supplied. If preferred, circuit and instructions only can be supplied for 1/6 post free. All items may be purchased separately. This is a highly efficient instrument, and a MUST for every radio man.

**5 HARROW ROAD, W.2** PADDINGTON 1008/9

**ADCOLA (Regd. Trade Mark)**  
SOLDERING INSTRUMENTS



Supplied for all volt ranges from 6/7v to 230/250v  
Meets every requirement for radio assembly, maintenance, telecommunications, etc. High Temperature, Quick Heating, Low Consumption, Light Weight

3/16" Dia. Bit Standard Model 22/6

1/4" Dia. Bit Standard Model 25/0

3/16" Dia. Detachable Bit Type 30/0

British and Foreign Patents

Sole Manufacturers: **ADCOLA PRODUCTS LTD.**

Registered Offices:—

**Alliance House, Caxton Street, S.W.1. (BRI 8075)**

# PREMIER RADIO

MORRIS & CO. (RADIO) LTD.

All Post Orders to: JUBILEE WORKS, 167 LOWER CLAPTON ROAD, LONDON, E.5 (Amherst 4723, 2763, 3111)

152 & 153 FLEET STREET, E.C.4 (Central 2833)

207 EDGWARE ROAD, W.2. (Ambassador 4033)

Open until 6 p.m. Saturdays

**SECTIONAL WHIP AERIAL.** Seven sections which plug into each other making an aerial 14ft. long. Thinnest section 1/4 in. diam., thickest section 3/4 in. diam. Weather-proof enamel. 3/6 each, complete.

**INSULATED BASE** for above, 1/6 each.

**R107. ONE OF THE ARMY'S FINEST COMMUNICATIONS RECEIVERS.** (See "W.W." August, 1945). 9 valves, R.F. amp. osc. Frequency Changer, 2 IP'S (465 kc), 2nd Detector, A.V.C. Af. amp. B.F.O. A.C. mains, 100-250v. or 12v. accumulator. Frequency range 17.5 to 7 mcs, 7.35 mcs to 2.9 mcs, 3.0 to 1.2 mcs. Monitor L.S. built-in. Complete. Write for full details. Price £12/12/0, plus 21/- carriage and packing.

**H. T. METAL RECTIFIERS.** 230v. 30 ma., 2/6; 260v. 30 ma., 3/-; 300v. 75 ma., 4/-; 250v. 120 ma., 5/-

**NEW 2-VALVE ALL WAVE KIT.** 16 to 2,000 metres. Switched Coil Pack ready wired and tested. 2 Mazda HL23 Valves. Phones. H.T. and L.T. Batteries, Condensers, resistors, diagrams and steel case, all ready to assemble, £3/10/0 including Purchase Tax.

**ALUMINIUM CHASSIS.** 16 S.W.G. Substantially made of bright aluminium with four sides.

	Price
7 x 3 1/2 x 2 in. ... ..	3/3
9 1/2 x 4 1/2 x 2 in. ... ..	4/-
10 x 8 x 2 1/2 in. ... ..	5/6
12 x 9 x 2 1/2 in. ... ..	6/8
14 x 9 x 2 1/2 in. ... ..	6/11
16 x 8 x 2 1/2 in. ... ..	7/3
20 x 8 x 2 1/2 in. ... ..	7/11
22 x 10 x 2 1/2 in. ... ..	10/-
10 x 9 x 3 in. ... ..	6/3
12 x 10 x 3 in. ... ..	6/10
14 x 10 x 3 in. ... ..	7/11
16 x 10 x 3 in. ... ..	8/6
20 x 10 x 3 in. ... ..	10/-

**MAINS NOISE ELIMINATOR KIT.** Two specially designed chokes with three smoothing condensers with circuit diagram. Cuts out all mains noise. Can be assembled inside existing receiver, 6/- complete.

**METERS.**

Full Scale Deflection	Scale Marking	Scale Length	Movement	Price
1 mA.	0-100	2 1/2 in.	M/C D.C.	15/11
1 mA.	0-1	2 in.	M/C D.C.	7/6
5 mA.	0-5	2 in.	M/C D.C.	5/-
30 mA.	0-30	2 in.	M/C D.C.	10/6
50 mA.	0-50	2 in.	M/C D.C.	8/6
150 mA.	0-150	2 in.	M/C D.C.	6/-
200 mA.	0-200	2 1/2 in.	M/C D.C.	8/6
2.5 Amp.	0-2.5	2 in.	Thermo	5/-
3 Amp.	0-3	1 1/2 in.	Thermo	5/-
3.5 Amp.	0-3.5	1 1/2 in.	Thermo	5/-
20 Amp.	0-20	2 in.	M/C D.C.	7/6
25 Amp.	0-25	2 1/2 in.	M/I D.C.	2/11
40 Amp.	0-40	2 in.	M/C D.C.	7/6
20v.	0-20	2 in.	M/C D.C.	5/9

**METERS—continued**

Full Scale Deflection	Scale Marking	Scale Length	Movement	Price
40v.	0-40	2 in.	M/C D.C.	5/9
300v.	0-300	1 1/2 in.	M/C D.C.	10/-
5,000v.	0-5,000	3 1/2 in.	Elect	50/-
500 u.a.	0-15 0-600	2 1/2 in.	M/C D.C.	5/-
500 u.a.	0-500	2 in.	M/C D.C.	7/6
500 u.a.	0-500	2 1/2 in.	M/C D.C.	19/6

**THE NEW PREMIER 1950 CATALOGUE**

Contains all the newest TV Kits, Components, Aerials, Tubes, etc., in addition to thousands of Radio Bargains.

Now ready—3d.

**SUPER MOVING COIL MIKE AND STAND.** We have purchased the entire stock of a famous Manufacturer of PA Equipment at a very low price, and are offering a £5/5/0 Super Moving Coil Mike, with a chromium plated folding stand to match. The list price of the stand was £3/3/0. **WE OFFER THE PAIR AT 79/6. LESS THAN HALF THE USUAL PRICE.**

**TRANSMITTING AND SPECIAL PURPOSE VALVES.**

705A ... ..	10/-	RL18 (CV1197) ...	5/-
861 ... ..	£10	803 ... ..	25/-
832 ... ..	10/-	HY114B (CV3505) ...	15/-
VS68 (CV1068) ...	6/6	MR300/E (CV3558) ...	15/-
EL266 (CV15) ...	40/-	1616 ... ..	5/-
805 ... ..	17/6	8012 ... ..	10/-
KB/S (CV160) ...	60/-	843 ... ..	5/-
E1191 (CV12) ...	60/-	1625 ... ..	5/-
EHTT (CV19) ...	60/-	U19 (CV187) ...	6/6
VT30 (CV1030) ...	7/6	956 (CV649) ...	3/6
U17 (CV1113) ...	5/-	NS2 (CV1199) ...	5/-
E1232 (CV92) ...	20/-	CV67 (Klystron) ...	5/-
PT25H (CV1046) ...	5/-	GU50 (CV1072) ...	7/6
VU133A (CV54) ...	6/6	1626 (CV1755) ...	3/6

**GOVERNMENT SURPLUS MAINS TRANSFORMERS.** All are for use on 230 volt 50 cycle Mains.

Type	Price
42 500-0-500v. 170 mA., 4v. 4a. ... ..	25/-
44 10v. 5a., 10v. 5a., 10v. 5a. ... ..	35/-
53 250-0-250v. 60 mA., 5v. 2a., 6.3v. 2-3a. ...	15/-
54 275-0-275v. 60 mA., 5v. 2a., 6.3v. 2-3a. ...	15/-
55 250-0-250v. 100 mA., 5v. 2a., 6.3v. 3-5a. ...	17/6

**METER KIT**

**A FERRANTI 500 MICROAMP M C METER,** with separate High Stability, High Accuracy, Resistors to measure, 15, 60, 150 and 600 volts D.C. Scale Length 1 1/2 in., diameter 2 1/2 in., 10/- the complete kit.

**5 KV. ELECTROSTATIC VOLTMETER.** Scale length 3 1/2 in., flush mounting, 4 1/2 in. diameter, £2/10/0.

**MOVING COIL EARPIECES.** Comprise a 1 1/2 in. Moving Coil Loudspeaker fitted with noise excluding rubber caps. Make excellent Mikes or Phones, 2/- each, 18/- dozen.



# Radio Constructor

Vol. 3, No. 8

Annual Subscription 16/-

March, 1950

Editorial Offices—57, Maida Vale, Paddington, London, W.9. Tel.: CUNningham 6518  
Advertising—Radio Constructor, 15, Charterhouse St., London, E.C.1. Tel.: HOLborn 8655

Edited by: C. W. C. OVERLAND, G2ATV

## EDITORIAL

**A**MONGST our readers there are participants in all types of radio interest. The following remarks are addressed to those who are devotees of the art of achievement using simple low power receivers, in other words QRP fans.

A study of reports sent in to radio periodicals by people using receivers and transmitters having an HT consumption of a fraction of a watt will give proof of the remarkable success which can be obtained, provided care is taken in construction and intelligence is used in operation.

Your Editor has recently had the honour to be appointed President of the QRP Research Group of the International Short Wave League, and invites all those readers of these pages who are interested in simple receivers or transmitters to take part in its activities.

The ISWL QRP Research Group issues a monthly journal entitled "QRP" to all its members. The annual subscription to the Group is 5s., plus the annual shilling subscription to the ISWL, of course, for those who are not already members. The journal is compiled from notes sent in by the members, and is a friendly production catering

for both the listening and transmitting, and the constructional sides.

A library of technical books and manuals is being built up at Group HQ, and it is proposed to loan these to members at a nominal charge to cover postage, etc. Contests are held regularly, and the Carter Shield has been presented by one of the members, to be competed for annually.

Incidentally, QRP does not necessarily mean using a minimum number of valves. In the most recent Group contest, for example, an HRO and an R107 took part—and occupied the last two places, though as far as DX was concerned they put up a good show. In these contests, the HT wattage plays an important part, and the building of a receiver which is as sensitive as possible, combined with the lowest HT consumption to permit satisfactory working, presents a challenge to the skill and ingenuity of the QRP fan.

Why not write for a sample copy of the QRP Journal and full details of membership, price 6d.? The address is J. Whitehead, Editor "QRP," 6 Abbot's Tilt, Hersham, Walton-on-Thames, Surrey.

G2ATV

## NOTICES

THE CONTENTS of this magazine are strictly copyright and may not be reproduced without obtaining prior permission from the Editor. Opinions expressed by contributors are not necessarily those of the Editor or proprietors.

THE EDITORS invite original contributions on construction of radio subjects. All material used will be paid for. Articles should be clearly written, preferably typewritten, and photographs should be clear and sharp. Diagrams need not be large or perfectly drawn, as our draughtsman will re-draw in most cases, but relevant information should be included. All MSS must be accompanied by a stamped addressed envelope for reply or

return. Each item must bear the sender's name and address.

COMPONENT REVIEW. Manufacturers, publishers, etc., are invited to submit samples or information of new products for review in this section.

ALL CORRESPONDENCE should be addressed to *Radio Constructor*, 57, Maida Vale, Paddington, London, W.9. Telephone: CUN. 6518.

# BUILDING YOUR OWN SIGNAL GENERATOR

By W. G. MORLEY

## PART FOUR

### Modulation

**M**ODULATING the RF oscillator is sometimes rather a difficult proposition. If the oscillator is oscillating strongly and comfortably anode modulation may have very little effect. Cathode modulation is sometimes effective but takes power from the AF oscillator and interferes also with the tuned circuit returns.

A very useful method of modulation is shown in Fig. 13. All that is needed is a resistor joining the grid of the AF to that of the RF oscillator. This may appear at first sight to be a somewhat drastic form of modulation, but, in actual fact, a really good depth of modulation may be obtained with coupling resistors having values as high as  $\frac{1}{2}$  M $\Omega$ . This value of resistor, compared with the usual 20 K $\Omega$  connecting the grid of the RF oscillator to earth, will have little effect on the RF circuits. The form of modulation is, of course, normal grid modulation, the coupling resistor and the RF oscillator grid leak together forming a potentiometer for the AF.

Modulation is switched in and out by breaking the HT to the AF oscillator anode. As the power

pack may not have a high degree of regulation, the change in HT current caused by switching off the modulator may vary the HT sufficiently to slightly alter the RF frequency on the "top" ranges. This may be overcome by using the circuit of Fig. 14. When the modulator is switched out, a resistor R is switched across the HT. The value of R is so chosen that it takes the same current as the modulator valve.

"External Modulation" may be provided, if required, by connecting the source of external modulation between the grid of the AF oscillator (when switched off), and chassis.

### Preventing Unwanted Radiation

The output of the signal generator is required at one point only—at the end of its screened output lead. We must therefore make certain that no undue radiation takes place elsewhere. We can prevent radiation from the coils by putting the signal generator in a complete metal box. Most commercial generators have an additional internal screen around the coils, but we need hardly go to those lengths ourselves.

Radiation along the mains lead is a possible source of trouble, and may be cleared by using the somewhat inefficient filter of Fig. 15 (a), or the much more effective filter of Fig. 15 (b). The chokes can be small "all-wave" components, and should be examined to see that they can carry the necessary mains current. The 0.01 $\mu$ fd. capacitors are liable to make the oscillator case and test leads a little "lively," as a small AC current will flow through them. There is no need to worry if the earthy output terminal sparks a little when touching the chassis of a test receiver. However, as a few slight shocks may also result, the user will soon see that the connections are made with one hand only!

### Accuracy of Calibration

To avoid any errors in reading the scale it is advisable to make the pointer mechanism as simple and foolproof as possible. The pointer used should be fixed directly to the tuning capacitor spindle. To avoid parallax errors, the pointer should be fixed as close to the scale as possible, and the part immediately over the scale should have a flat surface, its plane being at right angles

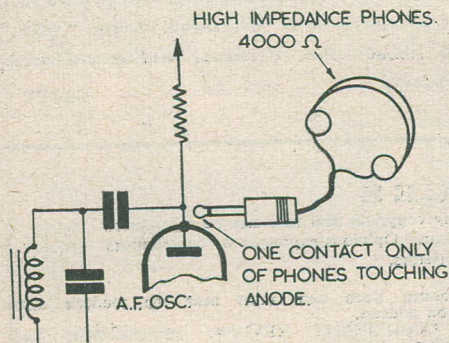
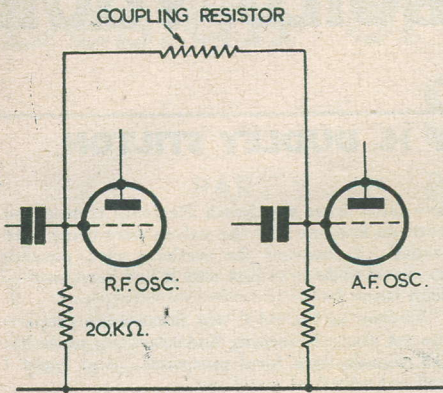

Fig. 12. A "dodge" for finding the frequency of the AF oscillator.



RC. 669.

Fig. 13. A method of modulating the RF oscillator.

to the surface of the scale, as is done in meter scales.

The completed signal generator may be calibrated against another instrument or against known commercial stations. In the latter case, spot frequencies may be marked at various points of the dial, a graph then being drawn to cover the complete range. The scale should be directly calibrated in frequency, as this will save a considerable amount of time when the instrument is put into use.

**A Typical Example**

A typical example of a home-constructed signal generator is shown in the photographs. This is an instrument built by the writer some three or four years ago when components were hard to obtain.

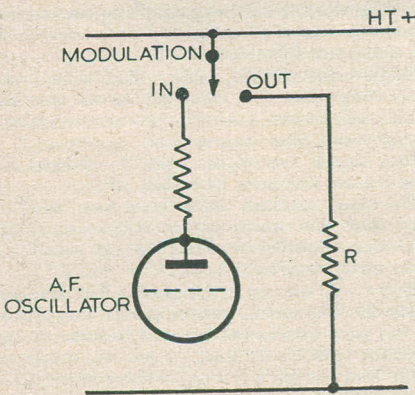

RC.670

Fig. 14. A switch circuit for the modulator (see text).

Apart from the electrolytic smoothing capacitors, all the parts were obtained from the spares box. It will be seen that the unit is quite compact and portable.

The tuning capacitor, a single-gang 0.0005μfd. component, is readily visible in the photograph showing the internals. To the right of this are the RF and AF oscillator valves. Between these and the panel are the coils, which are mounted very close to the range switch. Above the two valves can be seen the AF oscillator transformer.

To the left of the tuning capacitor is the mains transformer, a small home-wound job. Metal rectifiers were not available when this particular model was made and an American metal valve is used for rectifying the HT voltage. This is situated between the transformer and the tuning capacitor. Above it are two of the four mains filter capacitors.

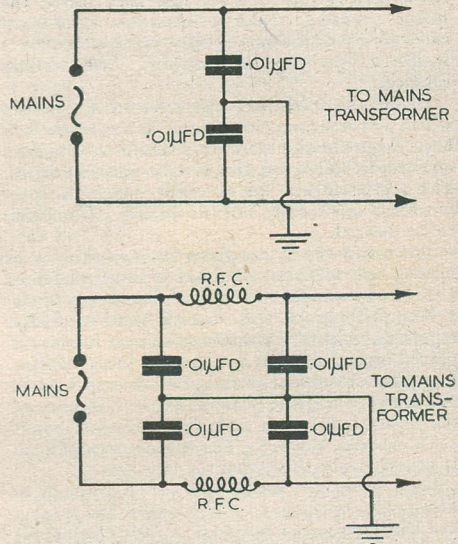

RC 671

Fig. 15. Above, a simple mains filter. Below, a much more effective filter.

The front view shows the layout of the controls. As large a scale as possible is used. A simple six-position attenuator, similar to that shown in Fig. 8, is used in this particular case. The range switch, "modulation in-out," and "internal-external" modulation switches complete the panel layout. In one position of the range switch the output of the AF oscillator is fed to the attenuator and thence to the output lead.

This particular signal generator did not take up a great deal of time in its construction, and, as stated above, the cost of its components was very low. It has been used almost continuously by the author since its construction; and it has repaid the small outlay in time and money many, many times.

# HOW TO RE-BUILD YOUR OWN SET

BY H. DUDLEY STILTON

NO service engineer will ever admit he is beaten; the excuses he will think up to cover himself could easily be entered into the realms of fiction. Not that there are many times per year that he needs to make excuses, for your modern service engineer is a highly skilled and competent worker. Excuse me while I re-arrange my halo.

If ever I get a set in that stumps me, my favourite excuse is that the set just isn't worth the money needed to repair it—then just as an extra salve to my conscience, I convince myself that it wasn't a very good set anyway. Still, it does rankle.

Before the war, there was a set on the market which was amazingly low priced. It was made for a large departmental store by, I found out too late, an exceptionally good firm of radio manufacturers. The set itself was an excellent one. The performance was terrific and the quality left nothing to be desired.

The other day I was given the opportunity of buying one of these sets, but a later model—a 1945 to be exact. The price was five pounds. I stumped up. I was warned that it needed repairing, that it was nothing serious because it played but would only get the two local stations. Any other attempt at getting stations only resulted in a series of whistles. So, as I said, I forked out the hard earned fiver and carted the job home.

To describe the set. The cabinet was perfect. It was the only thing about it that was.

I got it on the bench and sorted through it. The quality was lousy! No wonder, the speaker had hardly any cone left on it... 10/6 for having the speaker repaired.

The speaker when re-fitted brought forth not quality but a beautiful hum. I tried the electrolytics, in fact I tried everything before I saw it. The rectifier valve should have been a 5Z4G or equivalent but to my amazement I found a 6X5 sitting there looking quite at home. I flicked the chassis over and had a look at the wiring—it was a work of art. Someone had disconnected the earth from the filament pins and run another pair from them to the rect fil, which as you know on a 6X5 is, or are, separate from the cathode, then they had strapped cathode and filament together. That worked quite well—*except that all the valve filaments were running two hundred and seventy-five volts positive.*

Removing this arrangement and fitting a new valve (9/-) cured that trouble.

The quality was, however, still pretty rough. Tracing through the set showed why. The AVC line had been shorted to earth and, as we are only

five miles from the North Regional transmitter, you can imagine how the valves were being overloaded. I removed the earthing wire, puzzling the meanwhile as to just why it had been used—I soon knew!

As soon as the AVC was functioning properly the set started crashing and crackling more like DX signals than local reception. And could I find out why?—I could not!

Giving my badly troubled mind a rest, I transferred my attention to the coils and trimming, to try and overcome the heterodyne whistles. The coils themselves were very cheap and very crude, and they were also NBG.

I sat back and lit a cigarette.

I couldn't flannel myself with the excuse that the set wasn't worth repairing—remember I paid five quid for it—and yet, ironically enough, in this particular case, it was perfectly true!

At last I made up my mind. The set would have to come to bits and be re-built. I sorted through my service sheets until I found one that contained all the vital parts of the set I had. Then I ripped it down.

I had a good coil pack (25/6) and a pair of IF's (12/6) and starting at rock bottom, I built these into the chassis. From there on it was plain sailing.

Two nights later I finished the job and switched on. The pack and IF's were aligned and a signal tuned in—and with it came the same accused crackling which I had been unable to cure earlier. I spent the rest of the night in fruitless search for the cause, but I didn't find it!

Down came the set again. This time I put every component that came out on one side and re-built the set with entirely new components at a cost of—well, you work it out.

Once again, two nights later, I switched on. Now I know why men beat their wives.

The thing crackled as badly as ever and the only thing that would stop it was to short the AVC out—but that wouldn't do—or would it? I was sorely tempted.

There were just three things that had not been changed. The mains transformer (I substituted my test pack with no better result) and the tuning capacitor with its fly lead. I put my meter on the fly lead and got a reading of three ohms—*three ohms* on a piece of wire only three inches long. The things I called that piece of wire! Whew!!

So if any reader knows anybody who wants a good secondhand set for about, er, let's see—£45/10/0, I shall be obliged if they will let me know!!



# Design of the SUPERHET

PART 5

By R. J. CABORN

Continuing with our articles on the design of the superhet we intend this month to discuss the theory and working of the IF amplifier.

## The Frequency of the IF Amplifier

Now in the first article of this series it was stated that the most commonly met intermediate frequencies for broadcast reception were to be found in the frequency band 450 to 470 Kcs, saying that this had been found the most useful frequency band for normal requirements. Now that we have delved more deeply into the theory of the superhet in the articles devoted to the frequency-changer we may begin to see why IF amplifiers at this frequency are so often used.

To begin with, it is first of all undesirable that the signal frequency should at any time be equal to the intermediate frequency. The reason for this is that signals presented to the signal grid would be amplified by the IF amplifier at the same frequency, thereby causing instability, etc. (The signal frequency is always, of course, present at the frequency-changer anode.) In any case, even if the signal frequency were only within say, 15 Kcs of the intermediate frequency, it would cause whistles by beating with it.

Secondly, the IF frequency should never have a value equal to the oscillator frequency, since, owing to the fact that the oscillator frequency appears at the frequency-changer anode, this would be fed into the IF stages, completely preventing any other signals being received. If the oscillator frequency approached sufficiently close to the intermediate frequency, it also would cause whistles, etc., by beating with it.

In addition, the intermediate frequency should be sufficiently high to reduce second-channel interference so far as is possible. At the same time it must not be too high, or the oscillator frequency will be so far removed from the signal frequency that we will have difficulty in tracking. Also, if the intermediate frequency is too high, we will find difficulty in ensuring that our selectivity curve meets the requirements necessary for good adjacent channel rejection.\*

\*Adjacent channel interference is the name given to interference caused by stations having frequencies close to that being received. Sometimes these stations are sufficiently close for their carriers to beat with the required signal. Thus, if a receiver has poor selectivity it could be subject to adjacent channel interference.

It will be seen therefore that there are quite a few points to consider before we finally choose our intermediate frequency. Paying attention to the first two points let us examine the frequencies covered by the aerial and oscillator tuned circuits on the normal medium and long wave bands, assuming that our receiver has a 460 Kcs IF amplifier.

Now the medium wave range stretches approximately from 200 to 500 metres. In terms of frequency, this is 1,500 to 600 Kcs. Our oscillator would then cover (1,500+460) to (600+460) Kcs—i.e., 1,960 to 1,060 Kcs.

On the long wave band the range is from 1,000 to 2,000 metres; or 300 to 150 Kcs. Our long wave oscillator would therefore cover (300+460) to (150+460) Kcs, that is 760 to 610 Kcs.

It will be seen from these figures then, that the nearest approach to 460 Kcs in either the aerial or oscillator circuits is 600 Kcs (MW aerial), 610 Kcs (LW oscillator), and 300 Kcs (LW aerial). 460 Kcs (and thereabouts) therefore fits very comfortably into the frequency range of the normal broadcast receiver, without too closely approaching any of the aerial or oscillator frequencies.

## The Selectivity of the IF Amplifier

In the first article of this series we also stated that, owing to the fact that the usual IF amplifier uses at least four tuned circuits all designed to give their best at one peak frequency, then the selectivity offered by the IF amplifier is greater than that given by a TRF receiver.

At that stage of the proceedings we could not, however, point out that there is another very important reason for the selectivity of the IF amplifier. This has to do with the actual frequency relationships existing between the intermediate frequency and the signal frequency.

To make this clearer, let us assume that we have a superhet receiving a signal whose frequency is 10,000 Kcs, the intermediate frequency of the receiver being the conveniently round figure of 500 Kcs. Let us further assume that there is an interfering signal at 10,015 Kcs. Now we would need a relatively large amount of efficient tuned circuits, if they were tuned to 10,000 Kcs, to effectively reject a signal of 10,015 Kcs, as this is only removed from the required signal by

$$0.15\% \left( \frac{15}{10,000} \times 100 = 0.15\% \right).$$

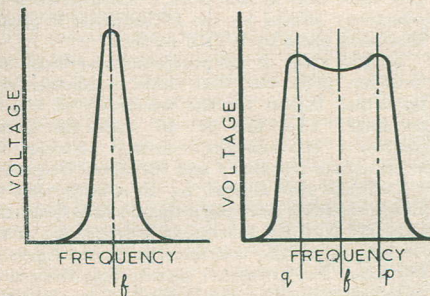
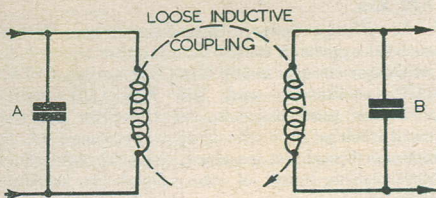
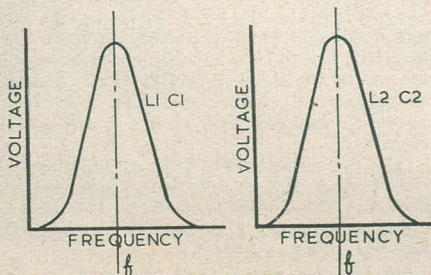
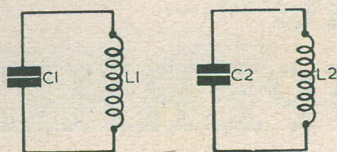

RC666

Fig. 1a—top.  
 Fig. 1b—second from top.  
 Fig. 1c—third from top.  
 Fig. 1d—bottom left.  
 Fig. 1e—bottom right.

When, however, the two signals have passed through the frequency-changer a very different state of affairs exists. The required signal now has a frequency of 500 Kcs. The interfering signal, which is also converted, appears on the anode of the frequency-changer as a signal of 515 Kcs. Now, it is quite simple to design tuned circuits for 500 Kcs which will reject a frequency of 515 Kcs because now the interfering signal is 3% off tune instead of the original 0.15%.

$$\frac{15}{500} \times 100 = 3\%$$

The obvious conclusion then is that, when the frequency of the IF amplifier is lower than the signal frequency, it has greater selectivity than that possessed by an amplifier with similar tuned circuits tuned to the signal frequency.

**Bandwidth**

When we use a superhet to receive modulated signals an important snag crops up. To understand this more fully let us see exactly what the reception of a modulated signal incurs.

Now, when a transmitter is modulated by an AF signal, sidebands are set up on either side of the original carrier frequency, these being removed from it by the frequency of the AF signal. For instance, if we were to modulate a 1,000 Kcs RF transmission by an AF tone of 5 Kcs, then we would find that we were transmitting not only the original 1,000 Kcs carrier frequency but also two sidebands of 1,005 and 995 Kcs respectively. The point here is that *it would be impossible to detect the signal and to hear the AF tone of 5 Kcs if our receiver did not accept the 995 and 1,005 Kcs sidebands as well as the original carrier of 1,000 Kcs.*

This necessity of receiving the sidebands caused by modulation has caused designers many a headache in the past and will probably cause many more in the future. Now, as the upper frequency limit of the ear is around 20 Kcs, it seems at first sight fairly obvious that for good quality reception we must not only receive the required carrier but also the band of frequencies on either side of it as far as 20 Kcs. If we were using a superhet fitted with, say, 465 Kcs IF transformers, this would necessitate the IF amplifier accepting a band of frequencies from 445 to 485 Kcs (i.e., 465-20 to 465+20 Kcs.)

Unfortunately, the broadcasting bands are so crowded these days that it is impossible to space stations apart in frequency by 40 Kcs; as would be necessitated by allowing sidebands as large as this. Stations on the medium wave band are, for instance, separated by only 9 Kcs, therefore allowing us theoretically to receive sidebands only to the order of 4½ Kcs. This allows a top audio frequency response of only 4,500 cycles, an extremely restricted range. However, the frequency allocations are so made that stations which are adjacent in frequency are well separated geographically. We may therefore hope for a higher top audio frequency limit on receiving local stations if they are sufficiently strong to

prevent any interference from stations in adjacent channels.

**Frequency Response of the IF Transformers**

Bearing in mind the fact that we must amplify not only the actual intermediate frequency as is given by the carrier of the required transmitter beating with the local oscillator, but also a series of sidebands dependent upon the fidelity of response we wish to obtain, then we may see that the design of our IF transformers becomes more difficult than at first appears.

However, good reliable IF transformers are readily obtainable by the home constructor, and these will already have been designed by the manufacturers to allow a certain bandwidth. In addition, constructors may nowadays purchase transformers designed to give a variable bandwidth by means of a panel control, thereby allowing the degree of selectivity to be adjusted.

**Band-Pass Circuits**

To enable the IF transformer to pass a fairly wide band of frequencies it is usual, in broadcast receiver technique, to employ what is known as band-pass coupling.

To understand what is meant by band-pass coupling let us assume that we have two tuned circuits  $L_2 C_2$  and  $L_1 C_1$  as shown in Fig. 1(a). These are each tuned to the same frequency  $f$  and the response curves of the two are identical, as is shown in Fig. 1(b). Suppose then that we mount the coils sufficiently close to enable a coupling to be effected via the mutual inductance of the two coils (see Fig. 1(c)). Their response curves would then "assist" each other, and if we were to inject a band of frequencies into  $C_1 L_1$  at A the frequency response curve obtained from the combination at B (Fig. 1(d)), would be sharper and higher than the individual curves of Fig. 1(b).

If, however, we were to progressively increase the coupling of the coils we would find that the sharp peak of Fig. 1(d) would increase to an optimum being then followed by a breaking up of the peaks into a double-humped curve as is shown in Fig. 1(e). This curve is caused by "over-coupling" the two tuned circuits and is typical of that given by a band-pass filter of which the 465 Kcs (or thereabouts) IF transformer which the 465 Kcs (or thereabouts) IF transformers found in the average broadcast receiver are typical examples.

If we examine the response curve of Fig. 1(e) we see that it has a broad top within a certain amount of frequency deviation on either side of  $f$ , and that it then falls off very rapidly. If the two co-ordinates  $p$  and  $q$  represented frequencies of  $f+5$  Kcs and  $f-5$  Kcs respectively, then a receiver possessing this response curve would receive side bands on either side of the carrier up to 5 Kcs, interference frequencies and further sidebands being heavily attenuated outside that range. The difference in frequency between  $p$  and  $q$  represents the "bandwidth" of the response curve.

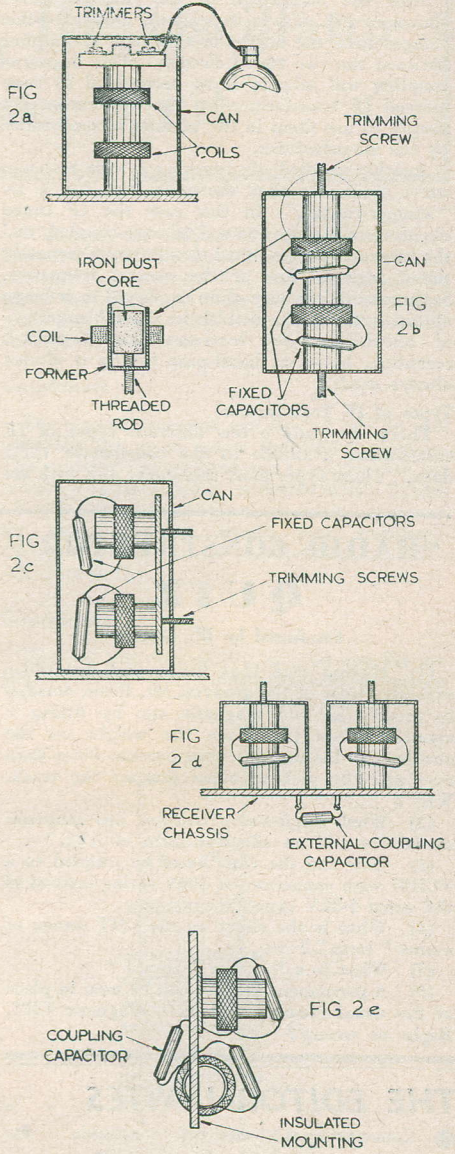

RC. 667.

Fig. 2a—top.  
 Fig. 2b—second from top.  
 Fig. 2c—third from top.  
 Fig. 2d—bottom left.  
 Fig. 2e—bottom right.

Now the bandwidth of the response curve shown in Fig. 1(e) is dependent, amongst other things, upon the degree or tightness of coupling between the two tuned circuits. This degree of coupling will already have been fixed in commercial IF transformers so the constructor has simply to use them in the manner recommended by the manufacturer.

Another method of obtaining a wide response curve similar to that shown in Fig. 1(e) is by "stagger-tuning." In this case the IF tuned circuits are lossely- instead of over-coupled, and the trimmers in the tuned circuits are alternately tuned high or low of the central frequency. Stagger-tuning is very often employed in order to obtain sufficient bandwidth in the IF amplifiers of television video receivers. For broadcast reception, however, band-pass tuning is almost always used.

**Types of IF Transformer**

There are quite a few different types of IF transformer available to the constructor these days. Those types most commonly met with are

shown in Fig. 2. Fig. 2(a) illustrates the most conventional type, the coils being mounted on the same former and the coupling being obtained by mutual conductance. In Fig. 2(b) we see a transformer which is tuned by adjustable iron dust cores, fixed capacitors being connected across the coils to provide the necessary tuning capacitance. The method of adjusting the iron dust cores is shown in the inset. In Fig. 2(c) the coils are mounted side by side (side by side mounting still allows sufficiently tight inductive coupling). Fig. 2(d) shows a method of capacitance coupling the two tuned circuits. The two coils, with their capacitors, are mounted in separate cans, an external capacitor coupling them together. In Fig. 2(e) capacitance coupling is again employed, but the coils are merely placed at right angles to each other to reduce inductive coupling. The ex-RAF R1155 uses IF transformers of this type.

**Next Month**

In next month's article we shall consider the IF amplifier as a whole, following this up by dealing with the detector circuits.

**"RADIO CONSTRUCTOR"**

**QUIZ**

*Conducted by W. Groomer*

- (1) Having read that heavy pick-ups cause excessive wear of the grooves, Mr. Brain decided to modify his old magnetic one by fitting a counterbalance to reduce the weight on the needle. To his surprise, tone became worse than ever and the pick-up often jumped the track. Why?
- (2) What single-valve receiver has immense sensitivity and an effective form of AVC?
- (3) How can the time bases be coupled to a VCR97 with capacitors of 500V rating instead of the usual 2-3kV type?
- (4) What is the effect on the CRT screen of mains "hum"?
- (5) What is a "sucker" circuit?
- (6) A permanent magnet can be used in place of the usual focusing coil on a magnetic CRT. Right or wrong?

**THE EDITOR INVITES . . .**

● **Constructional articles suitable for publication in this journal. Prospective writers, particularly new writers, are invited to apply for our "Guide to the writing of Constructional Articles" which will be sent on request. This guide will prove of material assistance to those who aspire to journalism and will make article writing a real pleasure!**

**ANSWERS TO QUIZ**

- (1) Mr. Brain's pick-up had an armature groove jumping.
- (2) The super-regenerative receiver. The AVC is actually a limiting action which holds all signals at the same level. Owing to its bad distortion, it is suitable for speech only and, further, it radiates strongly.
- (3) By earthing, or more accurately taking to chassis potential, the EHT positive. The only positive potential then above chassis is the ordinary HT, which may be connected to add its voltage to that of the EHT. Ordinary capacitors can be used to couple deflectors to time bases in this way. In point of fact, even these can be dispensed with, and the deflectors connected direct to the time base anodes, but unless the CRT is inherently good on spot centering the problem of line and frame shift is less easily solved.
- (4) Usually dark bands, moving when the time bases are free-running, and stationary when they are synchronized.
- (5) A rejector or trap for extracting an unwanted frequency. For example, a filter of this type is frequently used to remove television sound from the vision RF or IF circuits.
- (6) Yes, a permanent magnet of suitable design is now available. It should eliminate the focus drift caused by variation of current, for various reasons, passing through the focus coil in the usual arrangement.

# An Easily Built RF Oscillator EHT Power Unit

By H. Zimmerman

**T**HIS article describes the construction of an inexpensive EHT power supply for television, having an output of some 3.5 to 8kV, and operating from either AC or DC mains voltages of 200 to 250.

## Operation

The oscillator valve V1 is maintained in oscillation by coupling between the control grid and the anode via the two windings L1 and L2. The third winding L3 is closely coupled inductively to L2, and acts in conjunction with it as an RF transformer. The RF voltage developed across the anode winding L1 is stepped up across L3, and is then rectified by V2. C7 is the input capacitor.

Resistance-capacitance smoothing is used (R4 and C8), and a bleeder resistor R5 is connected across the output.

A half-wave circuit of the usual AC/DC type is used for supplying HT to the oscillator valve. This supply has choke-capacitance smoothing, and is also decoupled.

## Valves

The choice of valves is not critical, with the exception of V2. It is important that the oscillator valve should have a high output, as otherwise a low EHT will be produced.

## EY51 Heater Supply

It will be noted that the EY51 EHT rectifier (V2) has its heater supplied from a fourth winding (L4) on the RF transformer. Now it is obvious that the voltage developed across this winding will depend on the power in the primary circuit. It may be too low, in which case V2 will operate inefficiently, and it may be too high, when V2 will be burnt out. It is essential, then, to provide some means of controlling the power output of V2, and this can conveniently be accomplished by using VR1 to vary the screen potential.

It is also well worth while checking the voltage across L4 before connecting the heater of V2. This can be simply done by just connecting up a 6V torch bulb. Should there be any mishap, only a few coppers will be lost.

It is strongly recommended that the EY51 heater brilliance should be compared, after connecting up, to that of an EA50 running on a known 6.3V supply.

Whilst on the subject of the oscillator transformer, it should be remembered that a very high potential exists across L3, and care should be taken that no metal filings, solder, or wire clippings are allowed to stick to it, as this will probably result in a breakdown.

## Components

The components used are few, as can be seen from the list given below the circuit diagram. The values of the resistors and capacitors are not critical with the possible exception of R2, C2 and C3. The following suggestions are put forward for experiment to obtain best results:— C2—0.001-0.005 $\mu$ F. C3—0.003-0.002 $\mu$ F. R2—30k  $\Omega$  -300k  $\Omega$ .

## Construction

The RF transformer, V2, C7, C8 and R4 are mounted inside a screening compartment on top

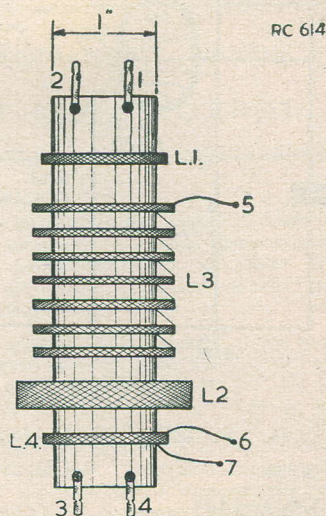

APPROX SIZE OF COIL & CONNECTIONS

of the chassis, and the EHT positive output is brought out through a feed-through insulator. The chassis and screen should be constructed of aluminium, copper or brass, and ferrous metals should not be employed. The chassis itself measures 10½" long by 5½" wide by 1½" deep. The screen consists of a "U" shaped piece of metal which forms the top and two sides, on to which is fixed the remaining two sides by flanges on the latter. Flanges on the ends of the "U" piece are used for fixing to the chassis. The screening can measure 5½" by 5½" by 5½", outside dimensions. S1 is a toggle on-off switch, and VR1 is a potentiometer of the pre-set type. If they were ganged, it would mean that the value of EHT would not be constant, and each time the unit was used there would be a danger of too high an output and thus a danger of too high a heater voltage for V2.

Half the top of the chassis is occupied by the screen. On the remaining half is mounted V1 and V3 along one edge, C4 and C5 along the centre,

and along the other edge the smoothing choke and mains dropping resistor. The latter should be kept well away from all other components.

**General**

The EHT supply given by this unit is of the "non-lethal" type, that is to say, the high voltage drops almost to earth potential at touch. But the unit as a whole is of the usual AC/DC type, which means that the whole of the apparatus of which this is part is connected to one side of the mains supply, and due precautions should be taken. VR1 will give, according to setting, an EHT output varying from some 3.5kV to 8kV, at 250µA maximum. If a lower value EHT is required, R3 may be increased.

The only way in which the EHT can be measured satisfactorily is by an electrostatic meter, several types of which are on the surplus market. A moving-coil type meter cannot be used as it presents far too much load and so gives a highly inaccurate reading.

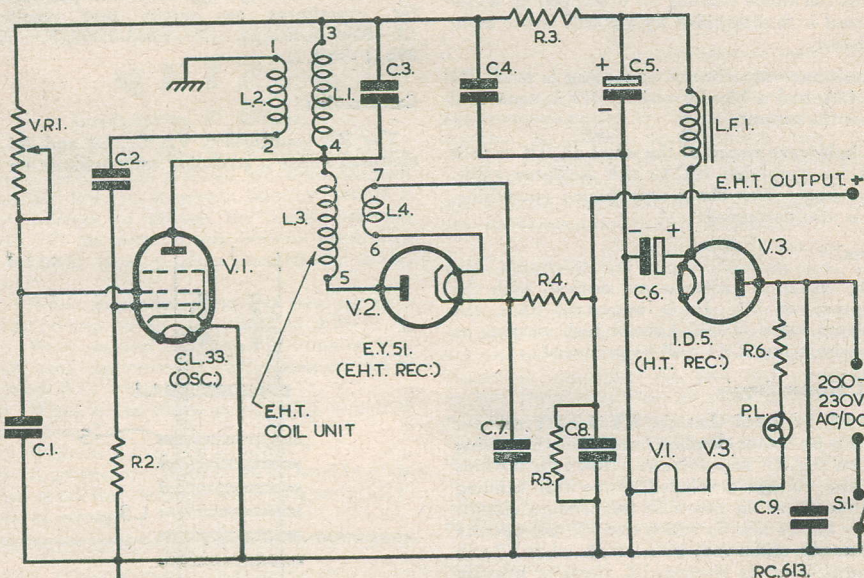

Circuit of the EHT Unit.

**COMPONENT LIST**

- |                         |         |                  |                              |
|-------------------------|---------|------------------|------------------------------|
| V1—CL33                 | V2—EY51 | V3—1D5 (0.2A)    | VR1—100k Ω pot.              |
| KT33C                   | 25L6    | U31, 25Y5 (0.3A) | R2—See text. ½W              |
| C1, 4, 9—0.1µF.         |         |                  | R3—500 Ω 1W                  |
| C2, 3—See text.         |         |                  | R4—100k Ω ½W                 |
| C5, 6—16.0µF, 350V wkg. |         |                  | R5—40M Ω ½W                  |
| C7, 8—0.001µF, 8kV wkg. |         |                  | R6—0.2A/0.3A to suit valves. |

EHT Coil 5.5kV—Hazlehurst Designs Ltd.

---

# Rebuilding an Ex-RAF RECEIVER, Type 1155

By J. COOK

---

**T**HE long suffering R1155 receiver has been adapted in many and various ways (vide articles in this magazine and others) but usually, one way or another, the performance and facilities fall short of those associated with the later types of communication receiver, as exemplified by the RCA-AR88, Hallicrafter SX28A or Eddystone 680, etc. Hence it is that, very often, the 'Ham' or short-wave enthusiast eventually scraps his R1155 and divests himself of some of his hard earned cash in purchasing one of these more advanced types of receiver.

In the author's case, however, it was decided that a really first-class communications receiver could be produced at a fraction of the cost using an R1155 as the basis. Moreover, it was considered uneconomic to utilise a separate domestic receiver for local 'quality' reception, so that the same equipment was required to fulfil this

The performance of the completed receiver is of a very high order combining, as it does, the high sensitivity of a communications receiver with the high quality reproduction of a TRF receiver feeding a push-pull Triode, Class 'A,' amplifier. Results on the higher frequencies with the converter unit, using double frequency changing, are exceptionally good also.

## Construction

The first step is to strip the R1155 chassis mercilessly of all components except the handles, tuning gang with its associated dial and slow-motion assembly, wave-range switch, the three coil units for ranges 3, 4 and 5 mounted above the chassis, the 'Jones' socket nearest the side of the chassis, the three IF coil units and complete sub-chassis coil unit. The latter two items, whilst being retained as a whole, should be modified as described later. The tube holders

---

## PRESENTING THE FIRST OF TWO INSTALMENTS OF THE WINNING ENTRY IN OUR RECENT RECEIVER CONTEST

---

function also — despite the difficulty that, normally, communications receivers are too complicated to be operated by non-technical members of the household.

It was thus that the receiver described in this article was evolved. The basis is an entirely re-built R1155 together with ancillary equipment comprising: converter for 5 to 10 metres, TRF unit with simplified control for medium-wave reception, TRF unit for television sound reception, dual speaker unit incorporating filter network and power pack unit supplying entire outfit. Whilst, perhaps, sounding ambitious the equipment can, nevertheless, be built up gradually. In any case, not all the above-mentioned facilities may be desired by the constructor. Economies can be effected, also, by replacing comparative luxuries such as the push-pull output stages by a single output tube, etc.

may also be retained but it may be found easier and advantageous to replace them with better quality components such as those of the 'Amphenol' variety, instead of the paxolin type employed.

It is necessary to cut a hole of the requisite diameter in the top right hand corner of the control panel to accommodate the 'S' meter. The meter illustrated is of  $2\frac{3}{8}$ " diameter and, in this case, it was found best to cut the hole as near to the edges as possible in order to clear the adjacent controls. The antenna trimmer is mounted alongside the 'S' meter in the position where the tuning indicator was originally fitted and it is therefore necessary to fit a plate, similar to those already carrying the audio gain and BFO pitch controls, to carry this component. A plate, measuring 6" x 3" and drilled for an 1 1/8" octal tube holder, is required to be fitted

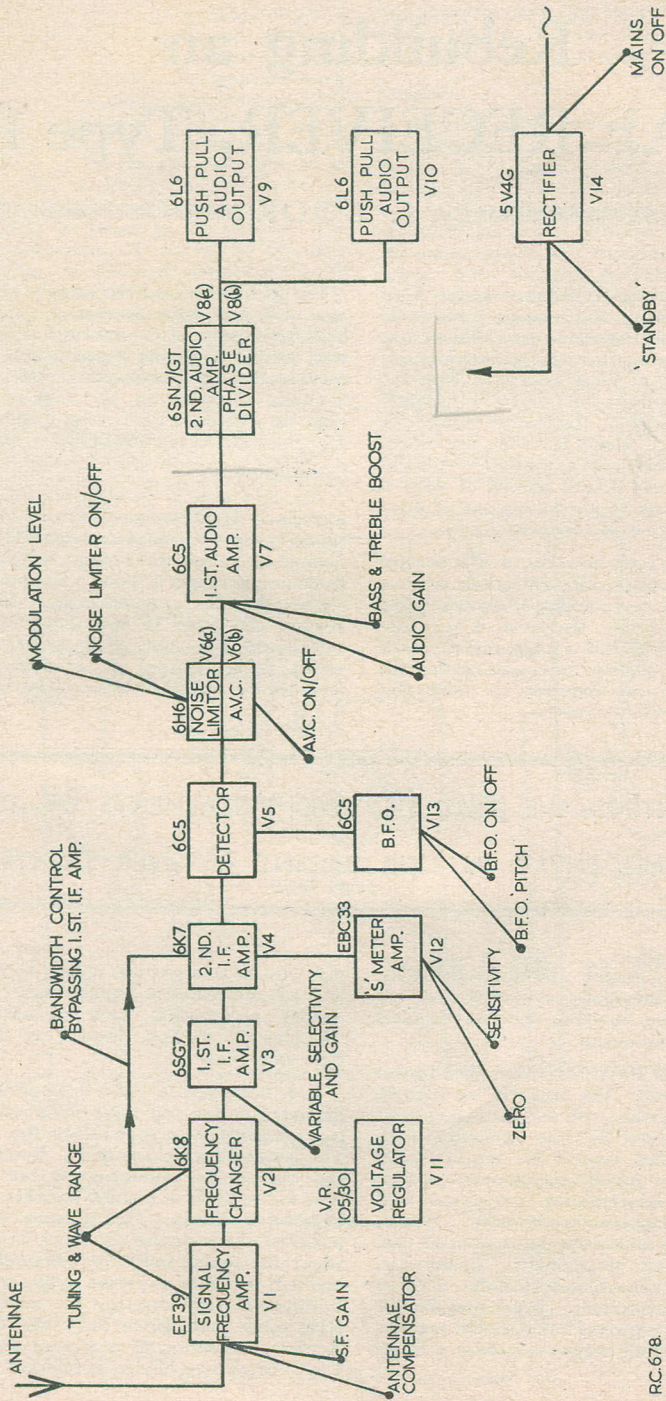

Block Diagram showing each stage with associated controls.



THE VALVE LINE-UP

Number on diagram	Function	Tube used (preferred type)	Alternative Type
V1	Signal Frequency Amplifier ✓	EF39	6K7
V2	Frequency-Changer ✓	6K8	ECH35
V3	1st. IF (Regenerative) Amp. ✓	6SG7	
V4	2nd. IF Amplifier ✓	6K7	EF39
V5	Infinite Impedance Detector	6C5	
V6(a), V6(b)	AVC and Noise-limiter	6H6 (metal)	
V7	1st. Audio Amplifier	6C5	6SJ7 (see remarks)
V8(a), V8(b)	2nd. Audio Amp. and Phase Divider	6SN7/GT	
V9, V10	Push-pull, Class 'A,' Triode connected amplifiers	Two 6L6 (metal)	Various
V11	Voltage Stabiliser	VR105/30	
V12	'S' Meter Amplifier	EBC33	6Q7/GT or metal
V13	Beat Frequency Oscillator	6C5	
V14	Rectifier	5V4/G	

to the chassis, below the 'S' meter and in line with the other two tube holders, to carry V8 and the output transformer. Another plate measuring 2 9/10" x 2 4/10" is fitted in place of the two 'Jones' sockets which have been removed to accommodate the two antenna input sockets and the two output jacks. Additional holes will be necessary to carry the selectivity, negative-feedback (if required), BFO on/off, HT on/off, noise-limiter bias, SF gain and 'S' meter zero controls. These modifications will be more clearly appreciated from Fig. 1. Dimensions are not indicated as they depend to a great extent on the size of the components used—small components are generally desirable in order to fit them in the available space. A small aluminium chassis, 2 4/10" x 5" x 1 1/4" is fitted above the receiver deck to house the beat frequency oscillator (in its original position) by means of angle brackets bolted to the existing holes.

It is a good plan to protect the tuning gang with a cover of some sort whilst the above modifications are being carried out in order to avoid the danger of filings lodging between the vanes—such an occurrence would be more than a nuisance! Finally, before the drill is laid aside, a word of warning. In order to avoid confusion between this receiver, when it is operating, and an electric toaster—it is both necessary and desirable to arrange for additional ventilation for the 13 tubes housed in such narrow confines. This can be accomplished easily by cutting a series of holes in two rows in the back and sides; a chassis cutter is a good tool for this purpose. At the same time, the fitment of rubber feet to the base of the cabinet will be found very useful to help clear the many cables under the cabinet, thus making a neat installation.

Before proceeding with the wiring side of the construction, it is assumed that the constructor will adhere to the good rules of radio; i.e., short

and direct wiring, substantial earthing, use of heavy gauge wire, etc. Further mention of these points will not, therefore, be made except where especial attention is necessary. It should be noted that neither side of the heater circuit is taken to chassis as a 3-volt potential will now exist between either of these points and chassis due to the centre-tapped transformer used. This arrangement reduces the chances of heater borne hum being introduced as, also, does twisting the heater wires together. These wires must be capable of carrying the load current without any drop as it must be borne in mind that up to 3 amps passes at some points.

**Signal Frequency Amplifier and Frequency Changer**

These two stages utilise EF39 and 6K8 tubes respectively, their bases being enclosed in the main coil switching unit. Two antenna input sockets are mounted on the front panel; one is provided for use with a long wire antenna whilst a co-axial socket is used for di-pole antenna or converter input. In the latter instance it is absolutely necessary for the input to be properly screened. A series capacitor is included in the antenna input and may be conveniently mounted outside the coil compartment.

The majority of the SF stage components are housed in the smaller of the two compartments and a number of modifications are necessary. The switch wafer, nearest the audio stages, which controls the primary of the input coil should be altered as follows:—

**Upper series of contacts:** The input from the antenna capacitor is connected to the key contact to feed coils on ranges 3, 4 and 5. Remaining wires are removed.

**Lower series of contacts:** The key contact is wired to chassis whilst remaining connections are unchanged.

The SFA coils for ranges 3, 4 and 5 are mounted

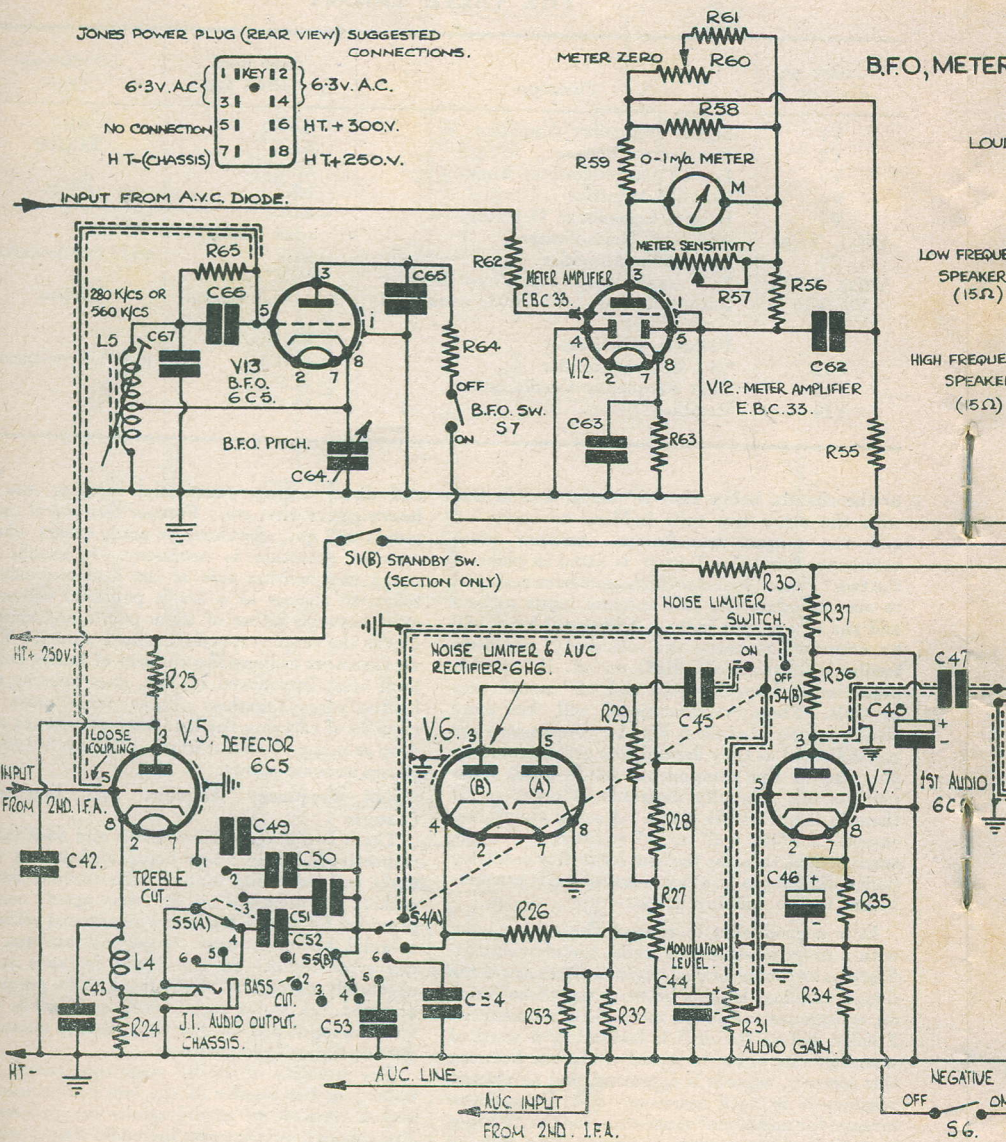

Fig. 2b. Circuit of the BFO, Meter Amplifier, Detector, Noise Limiter, Voltage Regulator, and Audio Stages of the Receiver. Component values are given on page 228. The circuit of the Signal Frequency Section is given on page 227.

# RADIO CONSTRUCTOR

## TER AMPLIFIER, DETECTOR, NOISE LIMITER, VOLTAGE REGULATOR & AUDIO STAGES.

### LOUDSPEAKER DIVIDING NETWORK

(CROSSOVER  $f = 1000$  c/s.)

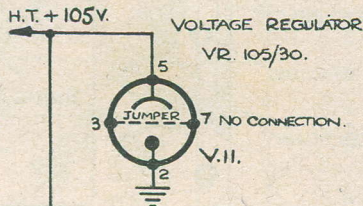
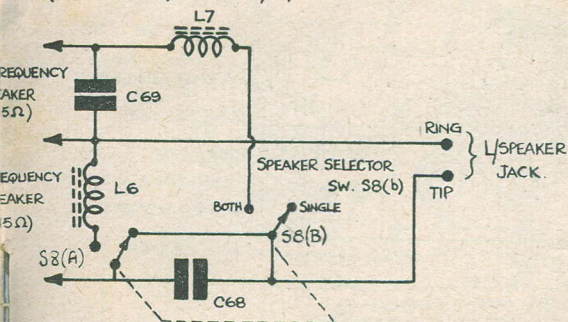

CONNECTIONS TO POWER PLUG.

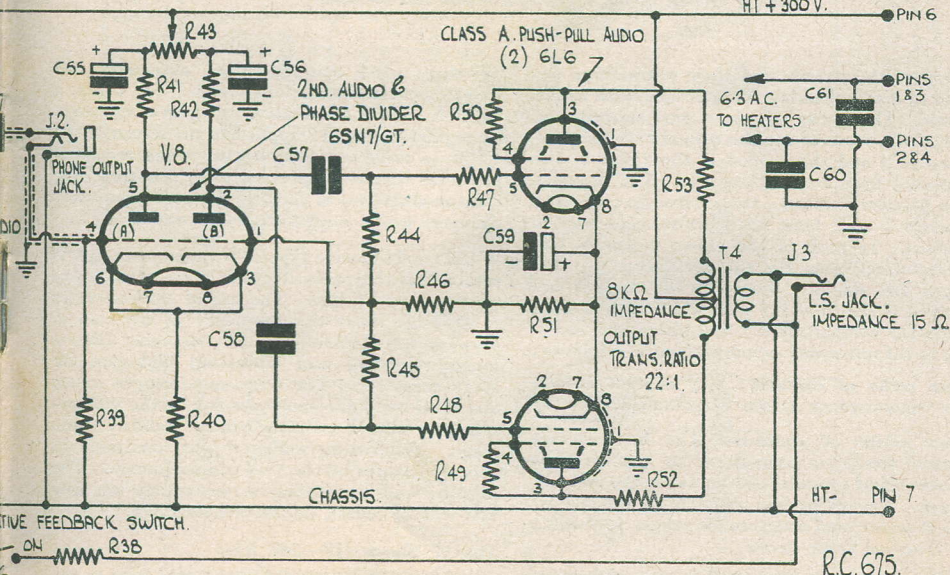

R.C. 675.

### Frequency Coverage of the Receiver

Range 1	18.5—7.5 Mcs (16.2—40 metres)
2	7.5—3.0 Mcs (40—100 metres)
3	1,500—600 kcs (200—500 metres)
4	500—200 kcs (600—1,500 metres)
5	200—75 kcs (1,500—4,000 metres)

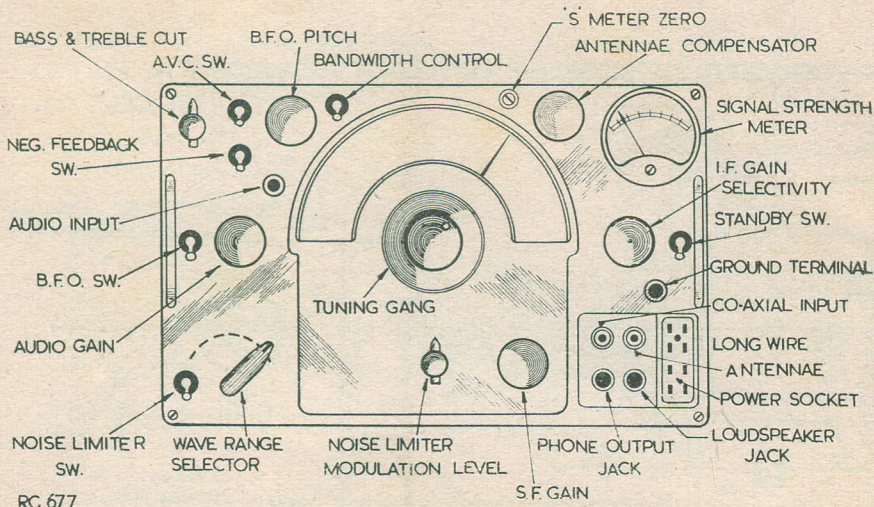

Showing revised layout of Control Panel (not to scale)

on top of the chassis and their connections are made to pins appearing through apertures in the chassis. The group of three pins nearest the edge of the receiver are the primary connections for range 4 and the nearest of these pins is disconnected from its earthing tag. The opposite three pins are connected to the secondary winding of range 4 and, here, the blue covered wire is removed. In each of the above instances, the corresponding pins for the remaining two LF ranges are similarly treated. No changes are required to the three HF coils which are mounted within the compartment. The alterations necessary to the remaining switch wafer are as follows :

**Upper series of contacts :** Key contact nearest inter-compartment screen is grounded.

**Lower series of contacts :** The key contact nearest screen is connected to the antenna capacitor and provides the input for the two HF ranges. Remaining key contact, on the reverse side of wafer, and contacts for ranges 3, 4 and 5 are removed from circuit.

The grid circuit filter unit in the SFA input (mounted on top of the LF range coils) is dispensed with although one component, the 160pF capacitor, is retained to maintain the tracking characteristics and is mounted under the chassis near the appropriate switch wafer. The lead from it to the tube grid is screened. However, the anode circuit filter, mounted in the middle of the larger compartment remains unaltered.

Two controls are provided for this stage. One is the variable antenna compensator C4 located on the front panel and it allows one to trim the

SF stage when using different antennae and also to correct the tracking errors. The other, a variable resistor R1, controls the gain of the stage by regulating the HT applied to the screen of the EF39—a most essential feature when receiving powerful signals to prevent the 'blocking' (or cross modulation) of the first detector (frequency changer) which might otherwise occur.

The triode-hexode type of frequency-changer is retained as the performance is quite satisfactory up to about 14 Mcs. The use of the converter is desirable above this frequency in any case in view of the double frequency-changing (better image rejection) and additional high-gain SF stage employed. The frequency-changer screen and local oscillator anode are fed by the voltage-regulator tube to assist the general stability of the stage. The switch wafers remain unaltered in this, the larger of the two compartments. The biasing and decoupling arrangements are new and will, of course, necessitate rewiring.

#### The IF Stages (IF—560 Kcs)

The first IF (6SG7) tube is located next to the main coil unit and in line with the SFA and frequency-changer tubes. It is with this stage that the first important departure from the original occurs, for this tube is made regenerative to give a degree of variable selectivity together with its single signal reception properties. This simple device gives very useful results by rejecting, in many cases, unwanted signals which may break through the first tuned circuits. Better results still may be obtained with a crystal filter circuit but the method used saves the considerable

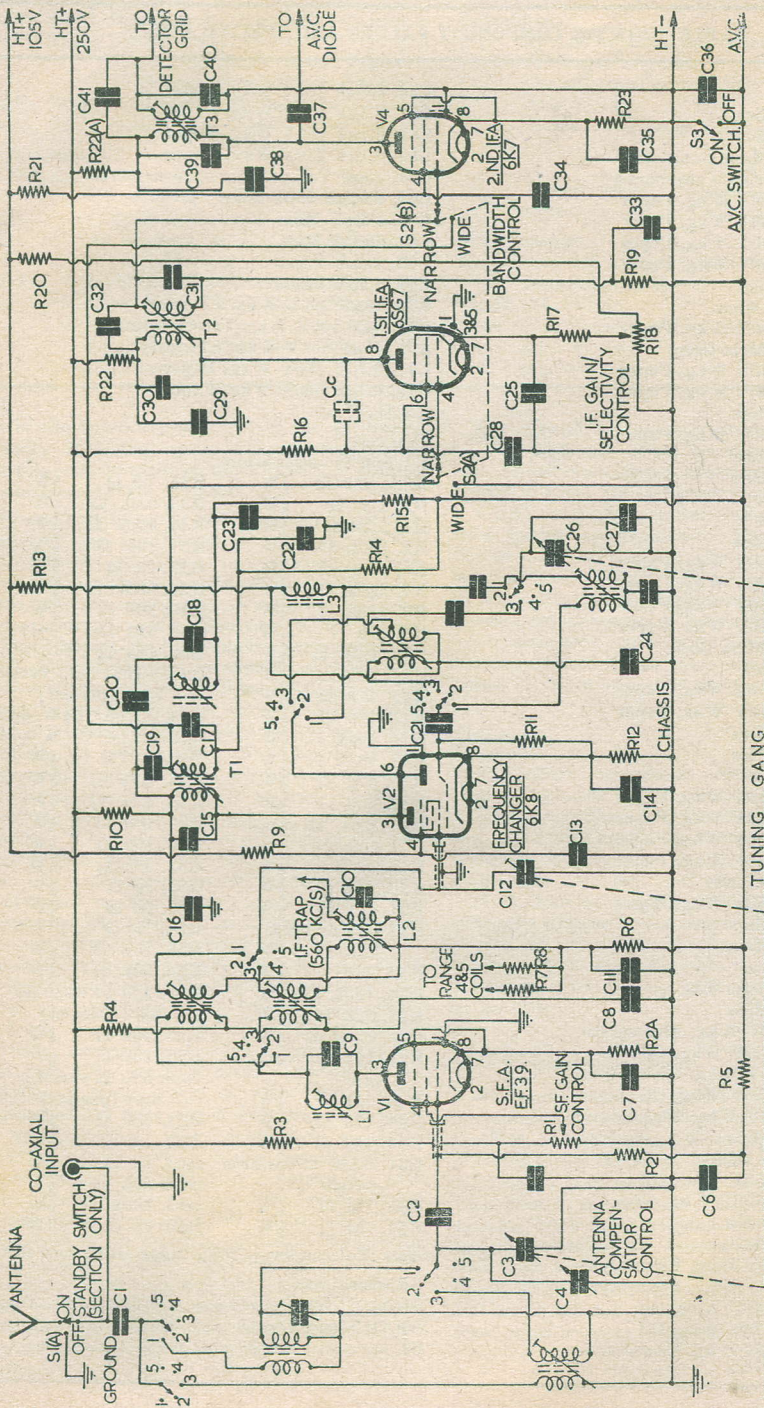

Fig. 2a. Circuit of the S.F.A., Frequency Changer and two IF Stages. Note: Only coils for ranges 1 and 3 are shown. Coils for ranges 4 and 5 are similar in design to those of range 3, and range 2 coils are similar to those for range 1. Certain switch sections, used to shunt out idle coils, are also omitted in the interests of simplicity, no modifications to the original being necessary in these sections.

RC676

TABLE SHOWING COMPONENT VALUES AND SPECIFICATIONS

Capacitors

- C1, 200pF Mica
- C2, 160pF Mica
- C3, Section Main Gang
- C4, 20pF Variable air-spaced
- C5, 0.5μF 350V Wkg, Paper
- C6, 0.1μF 250V Wkg, Paper
- C7, 0.1μF 250V Wkg, Paper
- C8, 0.1μF 350V Wkg, Paper
- C9, 160pF, Mica
- C10, 0.002μF Mica
- C11, 0.1μF 250V Wkg, Paper
- C12, Section Main Gang
- C13, 0.1μF 350V Wkg, Paper
- C14, 0.1μF 250V Wkg, Paper
- C15, 300pF Mica
- C16, 0.1μF 350V Wkg, Paper
- C17, 300pF Mica
- C18, 300pF Mica
- C19, 8pF Mica
- C20, 2pF Mica
- C21, 200pF Mica
- C22, 0.1μF 250V Wkg, Paper
- C23, 0.1μF 250V Wkg, Paper
- C24, 0.1μF 350V Wkg, Paper
- C25, 0.1μF 250V Wkg, Paper
- C26, Section Main Gang
- C27, 15pF Mica
- C28, 0.1μF 350V Wkg, Paper
- C29, 0.1μF 350V Wkg, Paper
- C30, 300pF Mica
- C31, 300pF Mica
- C32, 2pF Mica
- C33, 0.1μF 250V Wkg, Paper
- C34, 0.1μF 350V Wkg, Paper
- C35, 0.1μF 250V Wkg, Paper
- C36, 0.1μF 250V Wkg, Paper
- C37, 50pF Ceramic
- C38, 0.1μF 350V Wkg, Paper
- C39, 600pF Mica
- C40, 300pF Mica
- C41, 4pF Mica
- C42, 0.5μF 350V Wkg
- C43, 250pF Mica
- C44, 4μF 500V Wkg, Electrolytic
- C45, 0.1μF 350V Wkg, Oil
- C46, 25μF 25V Wkg, Electrolytic
- C47, 0.1μF 350V Wkg, Oil
- C48, 8μF 500V Wkg, Electrolytic
- C49, 400pF Mica
- C50, 0.002μF Mica
- C51, 0.1μF 350V Wkg, Oil
- C52, 0.25μF 350V Wkg, Oil
- C53, 0.001μF Mica
- C54, 0.01μF Mica
- C55, 8μF 500V Wkg, Electrolytic
- C56, 8μF 500V Wkg, Electrolytic
- C57, 0.1μF 350V Wkg, Oil
- C58, 0.1μF 350V Wkg, Oil
- C59, 50μF 50V Wkg, Electrolytic

- C60, 0.5μF 250V Wkg, Paper
  - C61, 0.5μF 250V Wkg, Paper
  - C62, 0.1μF 250V Wkg, Paper
  - C63, 0.1μF 250V Wkg, Paper
  - C64, 75pF Variable Air-spaced
  - C65, 0.01μF 350V Wkg
  - C66, 100pF Mica
  - C67, 300pF Mica
  - C68, 7.5μF Paper
  - C69, 7.5μF Paper
  - C70, 16μF 500V Wkg, Electrolytic
  - C71, 8μF 500V Wkg, Electrolytic
  - C72, 16μF 500V Wkg, Electrolytic
  - C73, 0.1μF 500V Wkg, Paper
  - C74, 0.1μF 500V Wkg, Paper
- Cc, See Text

Resistors

- R1, 50k Ω variable wire
- R2A, 220 Ω  $\frac{1}{2}$ W
- R3, 27k Ω  $\frac{1}{2}$ W
- R4, 2.2k Ω  $\frac{1}{2}$ W
- R5, 100k Ω  $\frac{1}{2}$ W
- R6, 150k Ω  $\frac{1}{2}$ W
- R7, 220k Ω  $\frac{1}{2}$ W
- R8, 220k Ω  $\frac{1}{2}$ W
- R9, 470 Ω  $\frac{1}{2}$ W
- R10, 2.2k Ω  $\frac{1}{2}$ W
- R11, 47k Ω  $\frac{1}{2}$ W
- R12, 270 Ω  $\frac{1}{2}$ W
- R13, 470 Ω  $\frac{1}{2}$ W
- R14, 100k Ω  $\frac{1}{2}$ W
- R15, 100k Ω  $\frac{1}{2}$ W
- R16, 47k Ω  $\frac{1}{2}$ W
- R17, 150 Ω  $\frac{1}{2}$ W
- R18, 2.5k Ω variable wire
- R19, 100k Ω  $\frac{1}{2}$ W
- R20, 47k Ω  $\frac{1}{2}$ W
- R21, 470 Ω  $\frac{1}{2}$ W
- R22 and R22(A), 2.2k Ω  $\frac{1}{2}$ W
- R23, 270 Ω  $\frac{1}{2}$ W
- R24, 150k Ω  $\frac{1}{2}$ W
- R25, 22k Ω  $\frac{1}{2}$ W
- R26, 220k Ω  $\frac{1}{2}$ W
- R27, 10k Ω variable wire
- R28, 40k Ω  $\frac{1}{2}$ W
- R29, 47k Ω  $\frac{1}{2}$ W
- R30, 30k Ω  $\frac{1}{2}$ W
- R31, 0.5M Ω variable carbon
- R32, 1M Ω  $\frac{1}{2}$ W
- R33, 1M Ω  $\frac{1}{2}$ W
- R34, 30 Ω  $\frac{1}{2}$ W
- R35, 6.5k Ω  $\frac{1}{2}$ W
- R36, 100k Ω  $\frac{1}{2}$ W
- R37, 18k Ω  $\frac{1}{2}$ W
- R38, 2k Ω  $\frac{1}{2}$ W
- R39, 560k Ω  $\frac{1}{2}$ W
- R40, 900 Ω  $\frac{1}{2}$ W
- R41, 42k Ω 1W ± 10%
- R42, 42k Ω 1W ± 10%
- R43, 10k Ω variable wire (pre-set)
- R44, 0.25M Ω  $\frac{1}{2}$ W ± 5%
- R45, 0.25M Ω  $\frac{1}{2}$ W ± 5%
- R46, 0.22M Ω  $\frac{1}{2}$ W
- R47, 4.7k Ω  $\frac{1}{2}$ W
- R48, 4.7k Ω  $\frac{1}{2}$ W
- R49, 100 Ω  $\frac{1}{2}$ W
- R50, 100 Ω  $\frac{1}{2}$ W
- R51, 375 Ω 5W
- R52, 50 Ω  $\frac{1}{2}$ W
- R53, 50 Ω  $\frac{1}{2}$ W
- R54, 7k Ω 10W
- R55, 10k Ω  $\frac{1}{2}$ W
- R56, 50k Ω 1W
- R57, 250 Ω variable wire (pre-set)
- R58, 600 Ω  $\frac{1}{2}$ W
- R59, 240 Ω  $\frac{1}{2}$ W
- R60, 550 Ω variable wire (pre-set)
- R61, 400 Ω  $\frac{1}{2}$ W
- R62, 1M Ω  $\frac{1}{2}$ W
- R63, 1k Ω  $\frac{1}{2}$ W
- R64, 50k Ω  $\frac{1}{2}$ W
- R65, 100k Ω  $\frac{1}{2}$ W
- R66, 1k Ω 10W

Note: Tolerances ± 20% unless otherwise stated.

Switches

- S1(A), S1(B), Double pole, Double throw, Toggle.
- S2(A), S2(B), Double pole, Double throw, Toggle.
- S3, Single pole, Single throw, Toggle.

- S4(A), S4(B), Double pole, Double throw, Toggle.  
 S5(A), S5(B), 2-pole, 6-way, Rotary.  
 S6, Single pole, Single throw, Toggle.  
 S7, Single pole, Single throw, Toggle.  
 S8(A), S8(B), Double pole, Double throw, Toggle.  
 S9(A), S9(B), Double pole, Double throw, Toggle.

**Inductances**

- L1, L2, L3, As original.  
 L4, RF Choke, effective at 560 kcs  
 17.0mH Eddystone.  
 L5, As original, or 560 kcs coil tapped  
 one-third from grounded end.  
 L6, L7, 3,400 $\mu$ H, DC resistance < 20  $\Omega$ .  
 L8, LF Choke, 13H at 100mA (DC  
 resistance 200  $\Omega$ ).  
 L9, LF Choke, 20H at 100mA (DC  
 resistance 470  $\Omega$ ).

**Transformers**

- T1, IF Coil modified as per text.  
 T2, T3, IF Coil as original.  
 T4, Output transformer, ratio 22:1 (Wharfedale W.12).  
 T5, Mains transformer, 350-0-350V 200mA,  
 6.3V CT 5A  
 5V 3A (Varley EP60)  
 T6, Heater circuit, booster transformer—if  
 necessary 6V 1.5A

**Miscellaneous**

- M, Moving-coil meter, 0-1mA FSD, 2 $\frac{1}{2}$ " flush  
 mounting, 75  $\Omega$ .  
 J1, J2, J3, Jacks.

*Note* : Specifications and/or types of component used in author's receiver are shown in brackets.

cost of the crystals and gets over the mechanical difficulty of finding space and mounting satisfactorily—not to mention the difficulty of obtaining suitable 560 kcs crystals.

However, this stage is only necessary when high selectivity and sensitivity are required; this is not normally the case when receiving strong signals for, under such circumstances, this stage of the receiver serves only to suppress the sidebands and introduce distortion which would seriously impair the high-quality performance of which the audio stages are capable of producing. In view of this fact, a switch has been introduced to cut the first IF amplifier out of circuit in order to offer a comparatively wide bandwidth when required. It will be observed from the circuit diagram that an additional 560 kcs coil has been introduced into L3 in order to feed V4 direct when the selectivity switch is in the "wide" position. This coil is mounted between the two existing coils in L3 and should be of a similar type. IF transformers for 560 kcs can sometimes be obtained on the surplus market but if the constructor has difficulty in obtaining this item he is best advised to pile wind a coil on a similar former using the data supplied by an Abac chart or, alternatively, by adapting a standard 465 kcs inductance removing turns by trial and error. All leads to and from the selectivity should be carefully screened and earthed—preferably at each end. The stage is made regenerative by soldering a short length of wire to the plate terminal of the tube socket and running it near the grid terminal. The capacitance, so introduced, is indicated by Cc in the circuit diagram. Regeneration is controlled by reducing the gain of the tube and R18 a variable cathode bias control services this function. The nearer the tube is operated to the point of oscillation, the greater will be the selectivity. Bias voltage is obtained from the voltage regulated line to ensure smooth and constant regeneration characteristics. Incidentally, without the capacitance Cc, the amplifier should be perfectly stable and show no tendency to oscillate at full gain.

The second IF stage uses a 6K7, selected because high gain is not necessary at this point and, as indicated above, functions as the sole IF amplifier when the selectivity switch is in the "Wide" position. Screen voltage is supplied from the voltage regulator. The centre tap on the primary of the last IF transformer is not required and the lead may be removed. It will be noted that in this, and the previous stages, the biasing arrangements of the original circuit have been dispensed with and individual cathode biasing is used; thus the receiver chassis is no longer 'live' in respect to the power pack chassis.

**Detector**

An infinite impedance detector (6C5) was chosen because it combines the high signal handling capabilities of the diode detector with low distortion (good linearity) and, like the plate detector, does not load the circuit to which it is connected. An RF choke is included in the cathode lead to suppress any RF which might otherwise appear in the output—this component should, of course, be effective at 560 kcs. The tube base is located alongside the third IF transformer in order to keep the input leads as short as possible.

**Beat Frequency Oscillator**

As already described, the BFO (6C5) is mounted on a separate chassis which provides increased stability and screening. Coupling to the second detector is by the small capacitance formed by running an insulated wire from the grid of the BFO close to the detector grid prong on the tube socket. Very little coupling is needed for satisfactory operation; the remainder of the coupling lead must be screened. The oscillator coil may be the original component (tuned to 280 kcs) or a 560 kcs IF coil and should be mounted nearest the front panel with the tube immediately to the rear.

*(To be concluded in next issue)*

# LOGICAL FAULT FINDING

*The eighth in a series of articles to assist the home constructor in tracing and curing faults*

By J. R. DAVIES

## 8: POOR SELECTIVITY—continued

### Poor Selectivity in a Superhet

A superhet is prone to several types of interference. These are:—

1. Adjacent channel interference.
2. Second-channel or image interference.
3. Interference caused by combinations of signals other than those causing the phenomenon of second-channel interference.

#### 1. Adjacent Channel Interference

This is the name given to the form of interference which occurs when the frequencies are sufficiently close to cause mutual interference. If they are very close to each other their carriers beat together giving an audible whistle which is very difficult to remove. An adjacent channel whistle is recognisable by reason of the fact that its note does not change as the tuning capacitor is rotated.

This state of affairs is very noticeable nowadays on the medium-wave band, it being difficult to tune in a weak station without a background of interference or whistles caused by other transmitters.

This leads to a certain amount of difficulty in the original design of a receiver. The manufacturer has not only to make his set selective enough to prevent adjacent channel interference, but has also to provide the receiver with sufficient band-width to allow reasonable quality of reproduction. Usually, a compromise is reached, although, nowadays, a variable selectivity control is becoming a welcome feature on many new commercial receivers.

So far as adjacent channel interference is concerned, the selectivity of the superhet rests almost entirely upon the performance of the IF section. The alignment of the IF transformers should be carefully checked, using a weak and steady signal picked up on the medium or long waves (never one on the short-wave band), or, better still, the output of a signal generator set to the correct frequency. All the IF trimmers should "peak" correctly (see above), and, should this not occur, either the particular tuned circuit will be found faulty, or the frequency chosen for the check is incorrect. Tests on faulty IF transformers usually involve a check of the coil and trimmers, followed occasionally by inspection of the external decoupling or valve circuits associated with them.

In the case of home-constructed receivers the IF transformer feeding the detector AVC circuits may sometimes be found to give a flat response, this being usually due to an incorrectly designed detection circuit which is introducing heavy damping on the secondary. In cases of doubt as to design, the adoption of the series diode detector circuit shown in Fig. 39 will give as good results as may be required, with little damping of the IF transformer secondary. The load resistor, R2, has the greatest damping effect, and should have a reasonably high value, never falling below 100K  $\Omega$ . (AVC, if required, may be taken from the junction of R1 and R2 in Fig. 39, and may be decoupled by a 1M  $\Omega$  resistor and a 0.01 $\mu$ F capacitor.)

#### 2. Second Channel or Image Interference

Second-channel interference is caused when a station, whose frequency equals that of the required signal plus twice the intermediate frequency, finds its way on to the signal-grid of the frequency-changer. To take an example, let us assume that we have a receiver whose intermediate frequency is 500 kcs. We want to receive a signal the frequency of which is, say, 1,200 kcs. The oscillator in the receiver will then be set to 1,700 kcs to provide the necessary 500 kcs difference. If there is another station of frequency 2,200 kcs, however, this will also beat with the oscillator to give 500 kcs and will thus find its way into the IF amplifier. The effect of second-channel interference is to cause a very irritating whistle whose note changes as the tuning capacitor is rotated.

The obvious cure for second-channel interference is to prevent the interfering signal from reaching the signal-grid of the frequency-changer. With the average commercial receiver produced nowadays, this is sometimes very difficult as there is usually only one tuned circuit between the aerial and the mixer. The alternative course is to make the alignment of the RF section of the receiver as good as possible, so that the required signal is then sufficiently strong to over-ride the second-channel transmission. For this reason, careful tracking of a receiver suffering from second-channel interference will usually eradicate the trouble. As the second-channel station may be picked up by the receiver wiring as well as by the aerial, the ideal receiver would be one in which



the RF and frequency-changer circuits are entirely screened. Unfortunately, few manufacturers go to the trouble of entirely screening their cheaper sets, and so the trouble is present to a greater or lesser degree on quite a few commercial receivers.

### 3. Interference Caused by Combinations of Signals other than Second-Channel

Whistles and interference in a superhet are occasionally caused by the heterodyning of various signals, their combinations being of a different nature than those causing the phenomenon of second-channel interference. The most commonly-met forms of interference peculiar to the superhet are reviewed below:—

(a) Let us return to the illustration given for second-channel interference. In this case we had a receiver whose IF was 500 kcs and which was receiving a signal of frequency 1,200 kcs. The oscillator in the receiver was set to 1,700 kcs. Now, suppose we have another signal whose frequency is also 1,700 kcs. This, should it reach the grid of the frequency-changer, will beat with the required signal (1,200 kcs) giving a heterodyne of 500 kcs, this being accepted by the IF stages. A signal of 700 kcs (1,200 minus 500 kcs) would also give rise to the same interference.

(b) Again, using the same illustration, let us suppose that the undesired signal has a frequency of 1,950 kcs. If this signal and the local oscillator in the receiver have a certain amount of second harmonic content, we may then have the effect of an undesired signal of 3,900 kcs beating with a local oscillation of 3,400 kcs, again giving a heterodyne of 500 kcs.

(c) If two strong signals whose frequencies differ by the intermediate frequency are both received and rectified by the frequency-changer, interference will again result.

(d) Harmonics of the IF, if picked up by the aerial circuits can again cause interference. Using our illustration once more, we find that this may occur when we are receiving a frequency of, say, 1,500 kcs. The third harmonic of the IF, if picked up in the pre-mixer stages, would beat with this signal causing interference.

(e) Yet a further example of interference is caused when signals at the intermediate frequency are picked up on the aerial and find their way to the frequency-changer. This is known as "IF Break-through" and the usual cure is either to change the frequency of the IF section, should a local station be causing the trouble; or to fit a rejector wave trap, tuned to the intermediate frequency, between the aerial and the aerial coil. The latter course is the better. IF wave traps will be found embodied in quite a few commercial receivers.

It may be seen from examining these various forms of interference that the cure for nearly all of them lies in adequate screening of both the RF and IF stages and in the use of adequately selective RF tuned circuits. In addition, the IF stages

should be so designed that they introduce little distortion to the IF waveform, thereby decreasing the possibility of harmonic generation.

### SUMMARY

#### POOR SELECTIVITY

##### Poor Selectivity in a Straight Receiver

- (a) Check trimming.
- (b) Check tuned circuits and associated components for faults.

##### Poor Selectivity in a Superhet

1. Adjacent channel interference.
  - (a) Check trimming of IF transformers.
  - (b) If trimming is unsatisfactory, check IF frequency, and look for faults in the IF transformers or their associated components.
2. Second-channel interference.
  - (a) Check trimming and padding of RF circuits.
  - (b) Check screening, if fitted.
3. Interference caused by other combinations of signals.

The treatment is the same as for second-channel interference above, except in the case of IF break-through, whereupon the best cure is to fit an IF wavetrap to the aerial circuit. Alternatively, the frequency of the IF section may be changed.

(To be continued)

## M. WILSON LTD.

Still satisfying customers at Home and Abroad. Our  
CIRCUIT No. 20

10 valves, 6 wave-bands, 12 watts  
(undistorted)  
Output Superheterodyne Receiver

Brief specification. R.F. stage of Amplification using 6 K7. H.F. Pen., the gain of which is controlled, followed by P.C. Triode Hexode 6K8 followed by I.F. Amp. stage 6K7 feeding into a double diode triode 6Q7 for L.F. Amp. and 2nd detector and noise limiter, followed by Phase inverter feeding 2-6V6 or 2-6L6 in push pull. Rectifier valve 5U4G. Visual tuning indicator (Magic eye EM34). The coil unit consists of 18 high "Q" iron cored coils, 6 each in R.F., H.F. and Osc. stages, all midget type, designed especially for us. 20 Ceramic trimmers and 3 bank switch, with shorting plates.

A.V.C. is used on all wave-bands with a switch for cutting out when not required. The coil unit is completely screened by 18 s.w.g. aluminium. The output transformer is of multi-ratio type mounted under the chassis. Controls R.F. gain, 6 wave-band coil switch, A.V.C. on/off radio-gram switch, noise limiter, tone-control, Audio gain and mains on/off. Provision for B.F.O. on/off if required. 3 gang tuning condenser Ceramic insulation, rubber mounted. All H.F. valves screened by aluminium cans. Double ratio slow motion drive and 6 wave-band dial glass covered Chassis 16 s.w.g. Aluminium, ready drilled  $12\frac{1}{2} \times 7\frac{1}{2} \times 4$ .

3 Fuses fitted 2 in mains supply and 1 in rectifier circuit. Provision for dipole Aerial and extension speaker P.U. sockets. This set is noted for its fine quality of reproduction on radio and gram. We have received much appreciation and congratulations from customers on its performance. A demonstration model is available at our premises at 307 High Holborn.

FULL SIZE BLUE PRINTS (2 practical and 1 theoretical) and priced list of components, 7/6 per set.

307 HIGH HOLBORN  
LONDON W.C.1. 'Phone: Holborn 4631

# Query Corner

## A "Radio Constructor" service for readers

### The Blocking Oscillator

"I read with interest the description of the operation of the transitron oscillator which was published in the last September issue of the magazine. Would you now publish similar notes on the blocking oscillator and at the same time tell me if this may be used in the time base of an oscilloscope."

B. Richards, Leeds.

The blocking oscillator, or squëgging oscillator as it is sometimes rather erroneously named, has of recent years proved very popular for use in the time bases of television receivers. This is mainly because it is reliable and stable in operation and is capable of being positively 'triggered' by the synchronising pulses. Blocking oscillators are, however, very rarely used in oscilloscopes because of the difficulty of maintaining a linear output waveform over a wide range of operating frequencies. The upper frequency at which satisfactory operation may be obtained is also limited by the stray capacitances of the circuit plus those of the feedback transformer. This is, of course, a rather serious objection to its use for oscillographic purposes.

Let us now consider the circuit of a typical blocking oscillator as shown in Fig. 1. The circuit makes use of a triode valve, a feedback

transformer having tightly coupled windings and a winding ratio of between 1:1 and 3:1. If the latter ratio is employed the connections to the transformer must be such that the winding having the greater number of turns is in the grid circuit. The operating cycle of this circuit is such that at the commencement of each stroke of the saw-tooth output waveform C1 is charged negatively so that the valve is biased beyond anode current cut off, and C2 is charged to a small positive potential. The charge on C2, and consequently also the voltage across C2, gradually increases due to the current which flows into this capacitor via R1. At the same time the negative charge on C1 is leaking away via R2 and the HT potentiometer. This is a progressive process which continues throughout the linear stroke of the saw tooth. As C2 charges so the anode voltage of the valve increases and similarly as C1 discharges so the negative bias on the valve is reduced. This stage of affairs continues until the bias voltage and the anode voltage is such that the valve commences to draw current. The increasing current passing through the primary of the transformer produces a voltage across this winding which in turn results in the induction of a voltage across the secondary. The polarity of the transformer windings is arranged so that the secondary voltage is positive when applied to the grid of the valve. This voltage, therefore, assists in still further increasing the anode current which in turn further increases the positive voltage at the grid. The effect is therefore cumulative and occurs in a very short space of time. The increasing anode current discharges C2 whilst the positive voltage at the grid of the valve results in the flow of grid current which recharges C1 negatively. The negative voltage building up across C1 soon equals the positive voltage applied to the grid from the transformer and the rate of increase of anode current is reduced. This in turn reduces the voltage at the secondary and the valve is rapidly biased beyond cut-off. At this stage the voltages developed across the transformer windings fall to zero and the whole cycle re-commences.

The waveforms indicated in Fig. 2 are those found at various points in the circuit, and it is suggested that the constructor may wish to assemble a blocking oscillator and examine these waveforms with the aid of an oscilloscope. Typical circuit values for a blocking oscillator of this type when employed in the line and frame time bases of a television receiver are given in the table below. The synchronising pulses may be applied to the grid as shown in Fig. 1 in which case they must be positive pulses. If negative

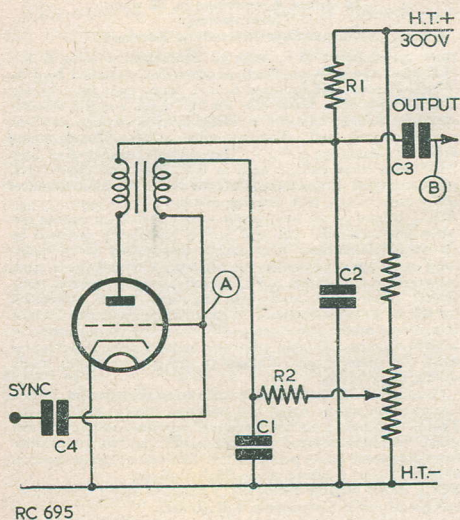

Fig. 1. A typical circuit of a blocking oscillator.

pulses are available they may be fed to the anode of the valve.

	Frame time base	Line time base
R1 .. ..	330K $\Omega$	330K $\Omega$
R2 .. ..	2.2M $\Omega$	330K $\Omega$
C1 .. ..	0.01 $\mu$ F	220pF
C2 .. ..	0.1 $\mu$ F	0.002 $\mu$ F
C3 .. ..	0.1 $\mu$ F	0.01 $\mu$ F
C4 .. ..	220pF	39pF

**Reflex Circuit**

*“ From time to time I have been told of the merits of the reflex type of circuit, but I have never seen a practical application of such a circuit. Would you please tell me if it suffers from any major disadvantages and, if possible, could you suggest a reflex circuit which I might use for experimental purposes ? ”*  
*H. Williams, Bradford.*

During the first five years of the 1930's there was much correspondence in the technical journals regarding the merits of the reflex system of obtaining increased amplification without the addition of further valves. For the benefit of those who may not have previously encountered the reflex circuit we will commence by describing the basic mode of operation. The reflexed valve is connected up as an RF amplifier but the anode load is divided into two parts, one part offering a high impedance to radio frequencies, and the other part offering a high impedance to audio frequencies. This latter part being shunted by a capacitor to by-pass the RF. Now the incoming radio signal is fed into the grid of the valve, is amplified and taken from the anode to the detector. From the detector the audio signal is fed back into the grid circuit of the same valve but this time it appears in amplified form across the audio anode load. After this it is fed into the remaining

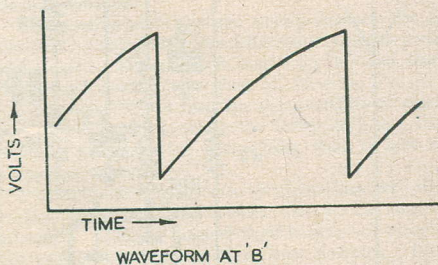
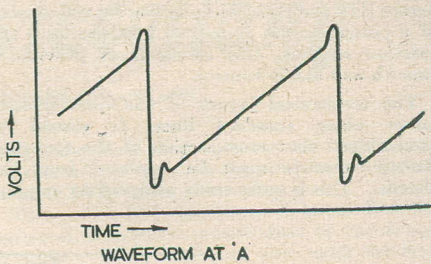

Fig. 2. Typical waveforms found in blocking oscillator circuit.

audio stage and hence to the speaker in the normal manner. The advantages of the system obviously lie in the increased gain which is obtained, but the disadvantages are the tendency to instability and the possibility of non-linear amplification. Needless to say, however, the advantages often outweigh the disadvantages and a number of commercial receivers have made use of this system.

**“ Query Corner ”**  
**Rules**

- (1) A nominal fee of 1/- will be made for each query.
- (2) Queries on any subject relating to technical radio or electrical matters will be accepted, though it will not be possible to provide complete circuit diagrams for the more complex receivers, transmitters and the like.
- (3) Complete circuits of equipment may be submitted to us before construction is commenced. This will ensure that component values are correct and that the circuit is theoretically sound.
- (4) All queries will receive critical scrutiny and replies will be as comprehensive as possible.
- (5) Correspondence to be addressed to “ Query Corner,” Radio Constructor, 57, Maida Vale, Paddington, London, W.9.
- (6) A selection of those queries with the more general interest will be reproduced in these pages each month.

The circuit diagram Fig. 3 is of a two-valve battery receiver which is capable of four-valve performance. The first valve is a triode pentode, the pentode section being employed in a reflect circuit as both RF and AF amplifier. The triode section of the valve operates as a standard leaky grid detector whilst the output stage follows normal practice. The RF load in the anode circuit of the first valve is obtained by means of an RF choke whilst the audio frequency load consists of the resistor R4. The capacitor C1 is in shunt with R4 and prevents the RF signal from being fed to the output pentode. The detector signal voltage is developed across R6 and hence also across R1 in the grid circuit of the first valve. The latter resistor is shunted to RF by means of C1. In order that the pentode section of the first valve should not be driven into grid current by the audio signal voltage a small negative bias is applied to it by means of the auto-bias resistor R11. Bias for the output pentode is obtained by virtue of the voltage drop

across R11 and R12. The reaction control consists of a potentiometer connected in series with the reaction winding, this arrangement provides a smooth and stable control.

The mechanical layout of the receiver may follow along standard lines. It should be remembered that once section of the two-gang tuning capacitor must be insulated from the chassis. This is quite easily achieved by employ-

ing two separate capacitors ganged together by means of an insulating flexible shaft coupler. In order to avoid instability all leads should be as short as possible.

In conclusion a word of warning; although this type of receiver is capable of giving a very good account of itself on medium and long wave it is not recommended for short wave DX work.

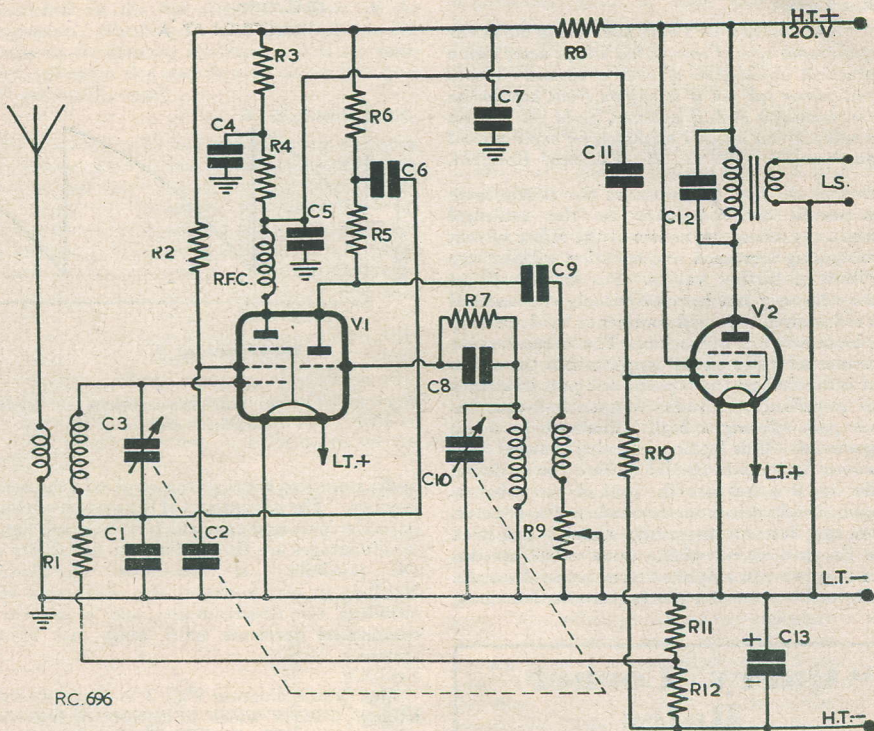

Fig. 3. A reflexed two-valve receiver.

Component list:

- |            |                   |
|------------|-------------------|
| R1, 100k Ω | C1, 0.001μF       |
| R2, 68k "  | C2, 2.0μF         |
| R3, 20k "  | C4, 2.0μF         |
| R5, 100 "  | C6, 0.01μF        |
| R6, 68k "  | C7, 4.0μF         |
| R7, 2M "   | C8, 100pF         |
| R8, 10k "  | C9, 100pF         |
| R9, 50k "  | C11, 0.01μF       |
| R10, 1M "  | C12, 0.001μF      |
| R11, 120 " | C13, 25μF 12V     |
| R12, 500 " | V1, KCF30 or TP25 |
|            | V2, KL35 or Pen25 |

# Radio Miscellany



**J**UDGING by the enormous number of books and periodicals to be found on the bookstalls and the flourishing Schools of Journalism, one might be tempted to believe that one half of our population are indefatigable scribblers and the other half either teaching or being taught the gentle art of writing. From this, too, one would expect that there would have been hundreds instead of a few dozen entries for the recent "Radio Constructor" Competitions—especially on ex-W.D. conversions. Who among us hasn't had some experience of that fascinating side of the hobby?

The reason can only be modesty. The feeling that there was really nothing particularly clever or original about their ideas.

Yet would-be entrants need only pause a moment to consider that there is little or no scope left for complete originality in amateur circles. What the Editor felt there was room for, was new applications for, or modified uses of, existing ideas.

The days when the amateur could hope to break into new ground with truly experimental work have long since passed. They only lasted for a fleeting spell. Experimental research, as distinct from personal interest experiment, is a job for the specialist in the fully equipped laboratory, but that should not discourage the amateur in what is essentially his own sphere.

While I should have been still happier to see an even bigger entry to these Competitions, there is good reason for gratification. A reasonable number sent in very good efforts, and this is a sure sign of the healthy and vigorous state of our hobby. On behalf of all our readers I extend warmest thanks and congratulations to the competitors.

and make sure they start on the right lines. Further advice on either the subject or its treatment is freely given.

Those who feel they have a latent flair for technical description, novel ideas or the design of amateur gear, need not wait until the next Competition—there is plenty of opportunity and a ready market waiting.

## Buried Treasure

The trouble with women, says a constructor, is that they don't know the difference between junk and Junk! From which might be inferred that radio junk stands in a class of its own.

I suppose 90% of humans are hoarders of some sort of old rubbish, while the other 10% are the ruthless scrappers of everything that is not of immediate service.

I once had neighbours, a Schoolmaster and ex-Schoolmarm, who were both inveterate hoarders. They cluttered their house, not simply the attic, with relics of their past hobbies. Bits of rock they called geological specimens, pressed flowers as botanical specimens, old pictures, prints, albums, scrapbooks, birds' eggs and what have you. When they had no living space left they moved to larger premises—an awful warning of the danger that attends acute cases of this form of mania.

The hoarding of junk is an individual thing; it does not run in families. At least, not in mine, which is only to be expected when it is remembered I had a Father who was a hoarder and a Mother whose favourite pastime was surreptitiously transferring things from his store of treasures to the ashcan. She handled this with all the cunning of her sex, always just before the refuse was collected so he stood no chance of retrieving it

## CENTRE TAP TALKS ABOUT

Radio Journalism — "Junk" — Programmes

### Situations Vacant

There is ample elbow room in amateur radio journalism for the would-be writer, and those of any promise are certain of Editorial encouragement. There are six British periodicals devoted to amateur radio and they all regularly invite contributions. Most of their Editors, if unable to use an effort, will suggest how it might be altered or "treated" to make it acceptable. The "Radio Constructor" sends on request a Guide to prospective new writers to save wasted efforts

She left it until she felt reasonably certain that he had forgotten of its existence and then—Hey Presto! it was gone.

As a consequence, I have one sister who is an unashamed hoarder of everything dear to the feminine heart. She could no more throw an old garment away without removing, and carefully saving, all the buttons, than the true constructor could scrap a chassis without removing every nut and bolt. Another sister ruthlessly scraps everything—even the daily paper isn't safe after nine

o'clock in the morning. Should you want to refer to it after that time you have to rummage for it in the salvage.

For my own part, I suspect I am a strange mixture of the two. To me a heap of someone else's junk acts like a magnet. I sort it out and examine each piece carefully, weighing the possibilities of its ever being put to any sort of use. Not that I have ever had much success in this quest. It is rare for me to find a piece that comes to anything useful although I have had a few marked successes with gadgets that I subsequently found I did not really need or keep in use after all.

My junk box, too, has been a constant disappointment. Whenever I feel the urge for a spring clean (due any time now), I usually start by slinging out all the bits I have kept for seven years.

Even the luke-warm junk saver can tell you that is a silly mistake. A need for those very pieces turns up within a month for sure.

There are two golden rules that every successful junk hoarder must constantly bear in mind. The first is, you simply have to go in for it in a whole-hearted way (half measures are plainly a waste of effort) and the second, keep a watchful eye on the opposite sex; particularly XYL's. Mothers are often fairly tolerant, but XYL's have been known to sabotage some really wonderful collections.

#### Waste Not—Want Not

Some months ago I described the radiogram built by a keen gadget-merchant, and I am suddenly reminded that the gift of successful gadgeteering stalks hand in hand with keen junk collecting. He can never bring himself to throw anything away. Deep down inside him there is a firm conviction that it is going to come in handy some day for something.

The gadgeteer is the man born with a natural gift for mechanics which he marries to an acquired taste for electricity; occasionally vice versa. If after combining these two he also turns to chemistry there is no telling where he will finish up. Probably making atom bombs.

A visit to his home can be a nerve-wracking experience, even for a strong, silent man. Bells ring and lights flash and it all means something. Either the baby is awake and crying, or the dog wants to go out or come in, or else the milk is about to boil over. Although these sudden warnings are liable to bring about a nervous collapse in normal mortals, the gadgeteer is rarely satisfied unless his indicator system produces a sense of urgency upon everybody within range. Rather like the effect a well-designed toggle switch has on a radio fan. You all know the thrill of pleasure you get as you "feel" it go over with a really smart snap.

Just as he can never bring himself to throw away anything that might have some use, he can never stand the thought of anything running to waste. "What," he says, "Waste surplus power in a line cord. Not Pygmalion likely!"

The volts to be dropped must not run to waste. They can be made to do something, even if it is to light a reading lamp no one is ever likely to read by.

#### Competition

Personally, I am not a regular listener although I do regularly sample most types of programme, just to make sure I am missing nothing. Some are good, some are indifferent and a few, very few, are outstanding. I always find the most depressing feature is the monotony of a regular pattern. The unwillingness to drop items which have gone stale even to the occasional listener, let alone the regulars. This fault seems inseparable from the over-organisation of a top-heavy administration you get with the present BBC set-up.

With others I have long advocated that at least a modified form of sponsored programme should be allowed, if only for the sake of its salutary effect on the pundits at B.H.

It has been a long struggle and with the growing tendency of recent years to crush the individual and glorify the State, the outlook has long since been pretty grim. Can we at last see a gleam of hope? Demands put to the Beveridge Committee to split the BBC into four zones each with complete Home Rule, is a step in the right direction. Even high BBC officials, nervous of the campaigning of the anti-monopolists, are thought to be ready to concede this much.

#### Studio Clagues

Why do the BBC studio audiences applaud all the artistes, good or bad, so thunderously? Even if there is some justification for the hit turns, there is certainly no need to give an equally 'big hand' to the third-rate. It would be far more to the point, and refreshing to the listener, to give some of the latter 'the bird.'

Perhaps there are two possible explanations. Firstly that the control Engineers turn up the "Gain" for the sake of effect, or secondly, the audience, having waited so long for the BBC to graciously allot them a studio seat, feel it is expected of them and any failure on their part to do what is required of them would be rank ingratitude. I think No. 2 must be the answer.

The roars of laughter with which very ordinary jokes often heard more than once in recent programmes, are greeted, indicates how willing the audiences are to pay for their seats in kind.

As for the first, from the listeners point of view, the terrible ear-splitting din which marks the end of the act ought to be faded down. Even if the act was outstandingly good there is no need to deafen the poor listener. After all, the show is supposed to be for him, not for the studio claque. Maybe the BBC have decided that the listeners are so half-witted that they will think a poor turn is a good one if they force him to rush to the volume control to defend himself from a splitting headache. When that follows a turn which he has been patiently waiting to finish in the hope that there may be something better to come, his annoyance at the din must be further increased.

# SURPLUS RADIO EQUIPMENT

described by B. Carter

In this series of articles it is intended to describe units that have (a) immediate application, after some modification perhaps, in the amateur world, and (b) to list the contents of those units that can best become sources of valuable components. This month's unit with very little modification may be of use to many amateurs as it is purchased.

## RECEIVER TYPE R1147A (10D/13123)

**T**HIS unit was designed to operate in the 200 Mcs region and can be modified to suit amateur 144 Mcs coverage. The chassis and case are built of aluminium sprayed with zinc, the lid and base are hinged to expose the LF valves on the top and the acorn valves through the IF screens underneath.

Power supplies are external to the unit and the connections may be unnecessarily complicated since the unit was designed for local and remote control. Should it be considered necessary the RF stages (V1 and V2) may be removed by unfastening the four 4 BA screws, two top and two bottom of the sub-panel, and removing the screws around the edge of the chassis which will now only just get through the hole in the panel. The 4-pin W plug 10H/391 will, of course, have to be unscrewed and so will the coil L1 from the shaft of the "Aerial" socket, it is advisable to remove all the valves during this operation. At this stage of demolition all the front panel appendages may be unfastened as well as all the chassis screws (not forgetting those hidden by the shock absorbers) and then the rest of the "insides"

will squeeze out through the base door. The tuning dial is marked for only a small angle as this is the maximum effective movement of the butterfly capacitors (C2 and C12), the viewing aperture may be in an awkward position but the dial can be turned around after removal of the 4 BA screws that are close to the 2 BA screws. A variety of knobs and cranks have been fitted to the central spindle, the tangential spindle is for cable attachment in connection with remote control.

V1	VR95	954	10E/95B	holder	10H/342
V2	VR59	955	10E/11452	holder	10H/341
V3	VR95	954	10E/95B	holder	10H/342
V4	VR99	954	10E/95B	holder	10H/342
V5	VR55	EBC33	10E/11401	holder	10H/493
V6	VR56	EF36	10E/11402	holder	10H/493
V7	VR56	EF36	10E/11402	holder	10H/493
Lamp	5A/1428	Holder	10A/11272	Glass	10A/11270 "Volume Increase" Knob
4 Lid Clips	10A/3371	4 Shock Mountings	Type 6,	3 lbs.	10A/9720
Switch	SL	10F/13358	Slow	Motion Drive	10J/71

### COMPONENT LIST

#### Resistors

R1 200K  $\Omega$  10C/11692  
R2 5K  $\Omega$  10C/11682  
R3 10K  $\Omega$  10C/27  
R4 100K  $\Omega$  10C/11691  
R5 5K  $\Omega$  10C/11682  
R6 20K  $\Omega$  10C/32  
R7 50K  $\Omega$  10C/11687  
R8 500K  $\Omega$  10C/129B  
R9 100K  $\Omega$  10C/11691  
R10 10K  $\Omega$   
R11 100K  $\Omega$  10C/11691  
R12 100K  $\Omega$  10C/11691  
R13 10K  $\Omega$   
R14 100K  $\Omega$  10C/11691  
R15 1M  $\Omega$  10C/1308  
R16 1K  $\Omega$  10C/11678  
R17 30K  $\Omega$  10C/10140  
R18 100K  $\Omega$  10C/11691

R19 1K  $\Omega$  10C/11678  
R20 10K  $\Omega$  10C/27  
R21 1M  $\Omega$  10C/130  
R22 100K  $\Omega$  10C/11691  
R23 2M  $\Omega$  10C/131  
R24 100K  $\Omega$  10C/11691  
R25 5K  $\Omega$  10C/11682  
R26 500K  $\Omega$  10C/129  
R27 500  $\Omega$  Pott. 10C/628  
R28 100  $\Omega$  10C/53

#### Capacitors

C1 3 $\mu$ F 10C/10301  
C2 Vari. Cap. Part of 10C/625  
C3 Trimmer. Part of 10C/625  
C4 .002 $\mu$ F 10C/8010  
C5 .002 $\mu$ F 10C/8010  
C6 5 $\mu$ F 10C/3393

C7 5 $\mu$ F 10C/3393  
C8 .002 $\mu$ F 10C/8010  
C9 50 $\mu$ F 10C/10568  
C10 .002 $\mu$ F 10C/8010  
C11 50 $\mu$ F 10C/10568  
C12 Vari. Cap. Part 2 of 10C/625  
C13 Trimmer. Part 2 of 10C/625  
C14 50 $\mu$ F 10C/10568  
C15 .002 $\mu$ F 10C/8010  
C16 .002 $\mu$ F 10C/8010  
C17 .002 $\mu$ F 10C/8010  
C18 5 $\mu$ F 10C/3393  
C19 .002 $\mu$ F 10C/8010  
C20 5 $\mu$ F 10C/3393  
C21 .002 $\mu$ F 10C/8010  
C22 .002 $\mu$ F 10C/8010  
C23 .002 $\mu$ F 10C/8010

C24	5 $\mu$ F	10C/3393
C25	.002 $\mu$ F	10/C8010
C26		10C/3396
C27	5 $\mu$ F	10C/3393
C28	50 $\mu$ F	10C/
C29	500 $\mu$ F	10C/626
C30	.005 $\mu$ F	10C/11697
C31	.002 $\mu$ F	10C/8010
C32	.01 $\mu$ F	10C/3419
C33	.05 $\mu$ F	10C/19629
C34	.25 $\mu$ F	10C/8382
C35	.25 $\mu$ F	10C/8382
C36	.003 $\mu$ F	10C/3394
C37	.001 $\mu$ F	trimmer 10C/827
C38	500 $\mu$ F	10C/626

C39	.002 $\mu$ F	10C/8010
C40	.25 $\mu$ F	10C/8382
C41	.05 $\mu$ F	10C/9629
C42	.005 $\mu$ F	10C/964
C43	.1 $\mu$ F	10C/10165
C44	2.0 $\mu$ F	10C/8275

*Transformers*

T1	1 F.T.	10K/12173
T2	"	10K/12174
T3	"	10K/12175
T4	"	10C/661
T5	Output	10K/162

*Plugs and Sockets*

A		10H/391
B	"Remote Control"	10H/393

C	"Supply"	10H/392
P	"Phones"	5C/590
BFO	"BFO"	5C/590
AE	"Aerial"	10H/160
X	"Earth"	—

Socket 10H/159 fits  
10H/160

Socket 5C/591 fits  
5C/590

L1 } Input 10C/602

L2 }

L3 }  
L4 } Osc. 10C/603

L5 }

L6 BFO note 10C/604

See Circuit on facing page.

## BIRMINGHAM INEXPENSIVE TELEVISOR

Through the courtesy of Mr. C. J. Shears, G3DNA, of Bletchley, Bucks. and U.E.I. Corp., 138, Grays Inn Road, W.C.1, we are enabled to give details of the use of the RF27 Unit in the "Inexpensive Televisor" for the reception of the Sutton Coldfield transmissions.

No constructional modifications are required, and it is necessary only to carry out alignment adjustment as follows:—

# OP-AID

Printed on good heavy paper, with durable stiff cover, the "Op-Aid" gives you the latest revised information about Distances, Amateur Codes and Abbreviations, Zone Boundaries, QSL Bureaux of the World, International and Amateur Prefixes, Call Areas, the Amateur Transmitting Licence, Morse Code, International Q and Z Codes, Standard Frequencies, and Local Time Conversion

PRICE 1/6 (post 2d.)

from your local supplier or direct from

**AMALGAMATED  
SHORT WAVE PRESS Ltd.**

57 Maida Vale, Paddington, London, W.9

'Phone : - - - CUN. 6518

- (1) Tune the IFT's to between 6.8 and 7 Mcs. (Screw in cores). Next adjust the oscillator coil padding capacitor for maximum noise. This capacitor is situated beneath the chassis, near the coil.
- (2) The mixer coil padding capacitor, also beneath chassis near coil, is next tuned to maximum capacity—indicated when the black lines are together.
- (3) The RF padding capacitor, also below chassis, is similarly tuned.
- (4) Next adjust the main tuning assembly for maximum capacity.
- (5) Short the aerial input to chassis to prevent 7 Mcs breakthrough, and then adjust the IF's to maximum noise level.
- (6) Remove aerial short, and connect dipole to aerial input jack.
- (7) Now adjust the variable trimmer of oscillator section, situated at rear of unit above gang capacitor, for maximum noise level, and leave.
- (8) Likewise adjust the trimmer of mixer section, situated in centre above gang, also for maximum noise.
- (9) Next adjust the trimmer above RF section of gang until the carrier of the sound channel is heard. This should peak with the gang almost at maximum capacity. The RF adjustment is rather critical and should be carefully made.
- (10) Now peak aerial input trimmer on front of unit.
- (11) Next tune main gang to about quarter capacity, when the video channel should be heard.
- (12) Final trimming can now be carried out, going over all trimmers in turn, as mentioned above, for maximum signal response, but the oscillator trimmer below chassis should NOT again be touched. The IF's will still, of course, require "staggering" for video use.



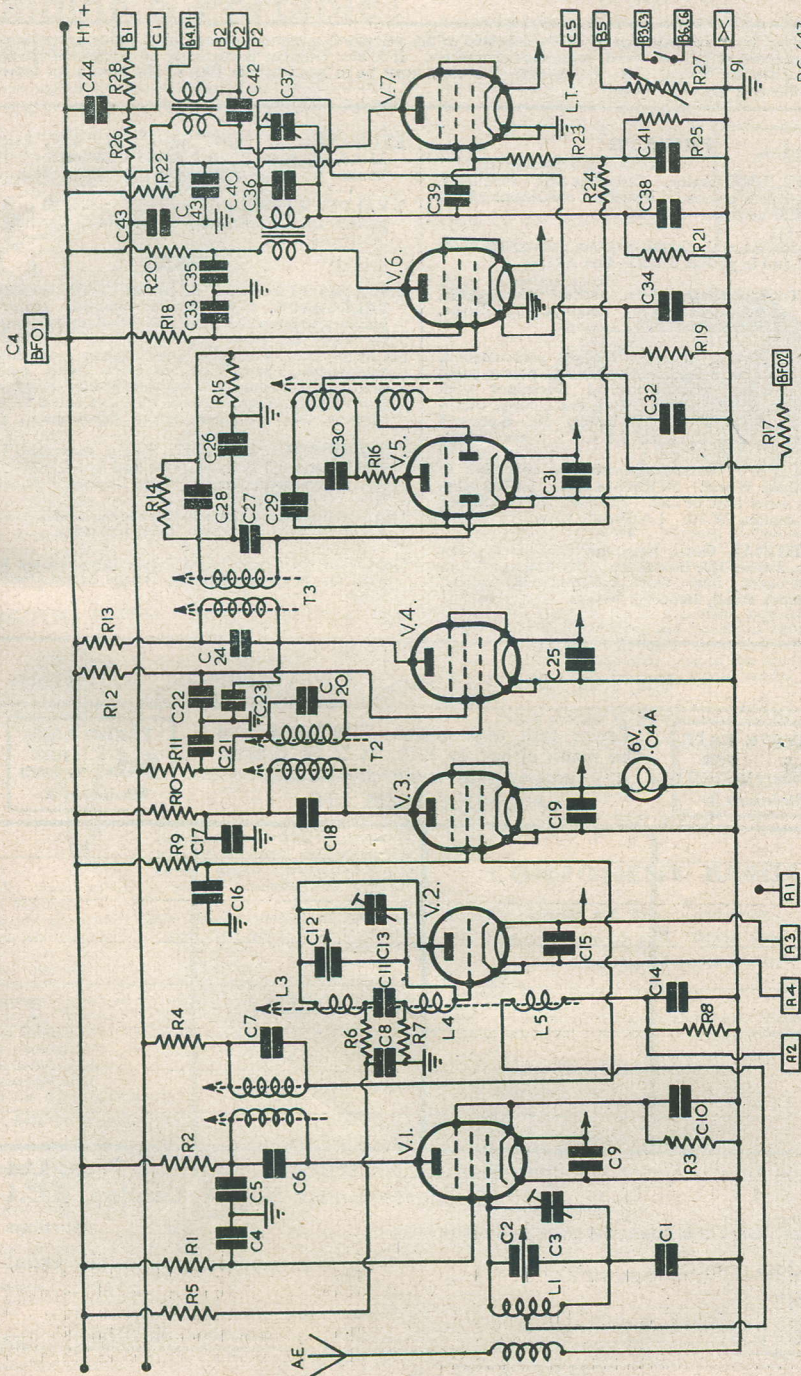

RC 647

Circuit of the R1147A Receiver.

# SMALL ADVERTISEMENTS

Readers' small advertisements will be accepted at 2d. per word, minimum charge 2/-. Trade advertisements will be accepted at 6d. per word, minimum charge 6/-. If a Box Number is required, an additional charge of 1/- will be made. Terms: Cash with order. All copy must be in hand by the 10th of the month for insertion in the following month's issue.

## PRIVATE

**FOR SALE.** HRO Senior. Complete pip. Five coils. All Ham bands covered. Excellent condition. Offer nearest £20 secures.—Box A115.

**WANTED MCR1** with circuit diagram ; complete outfit preferred and in perfect order.—Box A116.

**BOOKS,** Transformers, valves, various components, 4 valve short wave battery receiver.—H. Pryor, 1, Belle Vue Terrace, Saltash, Cornwall.

**R1155** modified with separate RF/AF gain control. S meter. Output stage. 200/250 AC power pack. Speaker. Phones. £9. Universal Avominor with 1,000v multiplier 5A shunt. 200Ω and 2,000Ω extension unit. £6/10/-.—F. J. Glover, 18, Knapmill Road, Bellingham, Catford, S.E.6.

**FOR SALE.** S.W. listener disposing of collection of parts. 42 W. World. 50 Radio-Craft. Callers only. Phone or write time of call.—Herman, 228, Ladbroke Grove, London, W.10. LADBroke 0749.

**INTERNATIONAL** Octal Valveholders (U.S.A.) few 2/6 dozen, five for 1/3. Box dozen 7193 valves, cartoned 16/-. All post free, lists available.—B. Carter, 22, Sycamore Road, Reading, Berks.

**EXCHANGE** 48 "S.W. News," 36 "S.W. Listener," 23 "S.W. Mags.," 16 "Radio Constructor," 12 odd books for 1224A Receiver or gear.—Box A118.

**7-VALVE RADIOGRAM** chassis new £9 ; R115A perfect £6.—37, Romilly Road West, Cardiff.

## TRADE

**ENGLISH ELECTRIC & MARCONI'S WIRELESS TELEGRAPH CO.** require qualified senior and junior television research and development engineers for their television departments at Liverpool and Chelmsford. Vacancies cover studio and domestic equipment. Unqualified engineers with extensive practical experience will be considered.—Write giving full details quoting reference TVG to Central Personnel Services, 24, Gillingham Street, Westminster, S.W.1.

**COMPONENTS.** Eddystone, Bulgin, Raymart, T.C.C. Wearite, etc.—Smith, 98, West End Road, Morecambe. Everything for all circuits. Send for lists or quotations.

**QSL's** and G.P.O. approved log books. Samples free.—Atkinson Bros., Printers, Elland, Yorks.

**G6MN** for the "best" QSL's and approved log books, send for samples : G6MN, Bridge Street, Worksop, Notts.

## USE THIS FORM FOR SMALL ADVERTISEMENTS

**PRIVATE RATE**  
**2d. PER WORD**  
Minimum 2/-

Terms cash with order. Payment should be made either by P.O., M.O. or cheque, crossed and made payable to  
**ALDRIDGE PRESS LTD.**

**TRADE RATE**  
**6d. PER WORD**  
Minimum 6/-

**To the Advertisement Manager 'Radio Constructor', Aldridge Press Ltd  
15 Charterhouse Street, London, E.C.1**

Please insert this advertisement under the heading.....for.....insertions

I enclose remittance.....s.....d. If Box No. required?.....(1/- extra)

**NAME**.....

**ADDRESS**.....

USE BLOCK LETTERS

# CLYDESDALE

Bargains in Ex-Services Radio and Electronic Equipment

Brand New in maker's original carton.

## TRANSMITTER TUNING UNITS.

Each having Vernier tuning dial; variable capacitors. Tank coil unit on ceramic former; ceramic switch; R.F. chokes, etc. In metal cabinet 17½ x 7½ x 8in. Finish black.

TU5B. 1,500-3,000 kcs.  
CLYDESDALE'S  
PRICE ONLY  
**22/6** CARRIAGE PAID  
each

TU6B. 3,000-4,500 kcs.  
TU7B. 4,500-6,200 kcs.  
TU8B. 6,200-7,700 kcs.  
CLYDESDALE'S  
PRICE ONLY  
**17/6** CARRIAGE PAID  
each

TU26B. 200-500 kcs.  
CLYDESDALE'S  
PRICE ONLY  
**10/-** CARRIAGE PAID  
each

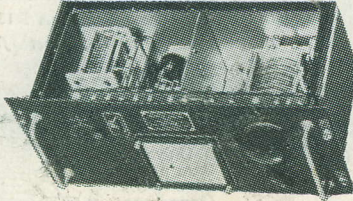

Brand New in original wood case,  
EX. CDN. ARMY, SUPPLY UNIT  
RECTIFIER, for No. 43 TRANSMITTER

Input: 110V.A.C. 50/60 c/s. 1.7 K.V.A. Outputs: 2,100V.H.T. 37 ma. 500V.H.T. 4,000 ma. 385V regulated. 450V.H.T. line. 275V.H.T. line. 415V. neg. bias. 250V. neg. bias. 150V. neg. bias. 80V. neg. bias. The unit consists of 3 complete power supplies, one of which provides various stabilised L.V. supplies. All are fed via double choke, condenser input circuits.

Other components include: Power trans. 2100-500-0-500-2100V. Power trans. 450-0-450V. 13v. ct. 6.3V. ct., 6.3V. Fil. trans. 2.5V. ct. twice. Fil. trans. 6.3V. (thermal) (arter). Chokes 2/15H. 375 ma. 2H. 450 ma. 2/15H. 110 ma. 20H. 160 ma. plus various H.V. condensers, resistors, etc. The complete unit mounted in metal case with lid 2ft. 6in. x 1ft. 6in. x 1ft., finish olive-drab crackle with shock absorbing feet. Wght. 420 lbs.

CLYDESDALE'S PRICE ONLY  
**£16** CARRIAGE PAID

### Power Unit 247

For 230 volts, A.C. 50 cycles, Output 600 volts at 200 ma., smoothed D.C. 6.3 volts, A.C. 3A.

Complete power pack, with 5U4G rectifier, etc., built on metal tray 10½ x 9 x 1½in. with grey finish metal cover 11 x 9½ x 7½in. 2 chromium handles, red indicator and inspection door, giving access to rectifier and pilot bulb.

CLYDESDALE'S PRICE ONLY  
**59/6** CARRIAGE PAID  
with transit box

R1481 Rack Mtg. V.H.F. R/T Receiver Unit.

Frequency 65-86 mcs. A 10 valve superhet, with 4/VR53 (EF39) VR54 (EF34) VR57 (EK32) 2/VR65 (SP61) VR66 (P61) VR67 (6J5G) plus, stabiliser VS70 (7475) "S" meter, screened R.F. section, B.F.G., etc., etc., in enclosed chassis, size 19 x 10½ x 11in., finish dark grey. Circuit supplied.

CLYDESDALE'S PRICE ONLY  
**£4/19/6** CARRIAGE PAID  
each

A.C. Mains Rack Mtg. Power Unit, Type 3 for R1481 and R1132. Input 0-200-220-240-250V. Output 200V. 40 ma. 6.3V. 3A. 4V. 1.5A. Complete with 0/300V. and 0/150 ma. meters, valve amplifier, fully smoothed, encl. chassis, size 19 x 7 x 11in., finish dark grey.

CLYDESDALE'S PRICE ONLY  
**£2/19/6** CARRIAGE PAID  
each

SPECIAL OFFER  
Receiver and Power  
CLYDESDALE'S  
**£8** both units  
CARRIAGE PAID

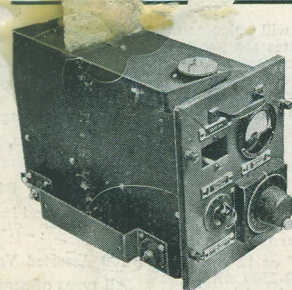

Ex. Cdn. Forces. A few only.  
V.R.L. Rack Mounted Communications Receiver. Made by Vancouver Radio Lab.

Frequencies 1.5-28 mcs. plus overlap. (200-10.7 metres). For 110-115V.A.C. mains operation, a 115-230V. Auto Transformer is supplied. This 19 valve receiver is a double converter, with one R.F. stage, separate local oscillator, B.F.O. and Noise limiter, and I.F. of 1.5 mcs./465 kcs.

Valves: 6K7, R.F. 6L7, 6K8, mixers, 6SJ7 L.Osc., 2/6K7's, 6L7, 6H6, I.F.'s, 6K7, 2nd det. 6H6, A.V.C. 6J7 B.F.O. 6SF5 1st audio, 6K6 audio output, 6G5 tuning ind., 80 Rect., VR150/30 stabiliser, 6K6G, 6C8G, 6K7, frequency std. All controls including B.F.O., separate A.F. and R.F. Gain, 2 speed tuning, wavechange, etc., mounted front panel. Receiver mounted lower part of rack, 6in. speaker/Power Unit mounted above, with 10-100-1,000 kcs. sub-standard. Also a complete set of spare valves. Dimensions: Receiver: 17 x 15 x 11½in. with 19in. rack panel. Dimensions: Power Unit: 17 x 8½ x 7½in. with 19in. rack panel. Plus angle iron rack overall dimensions: 19 x 24 x 12in. Finish grey crackle with black and chrome control finger plates.

CLYDESDALE'S PRICE ONLY  
**£30** CARRIAGE PAID

Ex. Army. WS-18 Receiver Unit. A 4 valve superhet chassis, range 6-9 mcs. (500-33.3 metres).

With ARP12 (VP23) F.C. 2/ARP12's L.F. and AR8 (HL23DD) Audio Loc. Osc., 2nd det and A.V.C. slug-tuned I.F. trans. 465 kcs. etc. The complete receiver mounted on a chassis 8½ x 5 x 1in. all controls front panel 9½ x 5½in. Unused, good condition.

Power requirements approx. 3V. 0.2A. L.T., 120V. 15 ma. H.T. 1.5V. bias.

CLYDESDALE'S PRICE ONLY  
**17/6** CARRIAGE PAID

Brand New, in maker's carton, Ex. U.S.A.S.C. Crystal Multiplier, Type MI-19468.

A frequency Multiplier to cover 2-20 mcs. with 807 and spare (2 valves), 0/10 ma. grid current meter, variable condenser, calibrated micrometer control, etc., external power supply required (no Xtals supplied). In metal case 13 x 10 x 6in. With Instruction Books.

CLYDESDALE'S PRICE ONLY  
**39/6** each CARRIAGE PAID

ORDER DIRECT FROM:

**CLYDESDALE** SUPPLY CO LTD

Phone: SOUTH 2706/9

2 BRIDGE STREET  
GLASGOW - C.5

VISIT OUR BRANCHES IN SCOTLAND, ENGLAND AND NORTHERN IRELAND